

CO1603

ECN # or INIT	REV	DESCRIPTION	DATE
OE-005	A1	REDRAWN TO AutoCAD	06-DEC-2012
OE-013	A2	CORRECTED HOOP PROFILE	19-APR-2013

SECTION A-A
(SHOWN W/ PLUGS REMOVED)

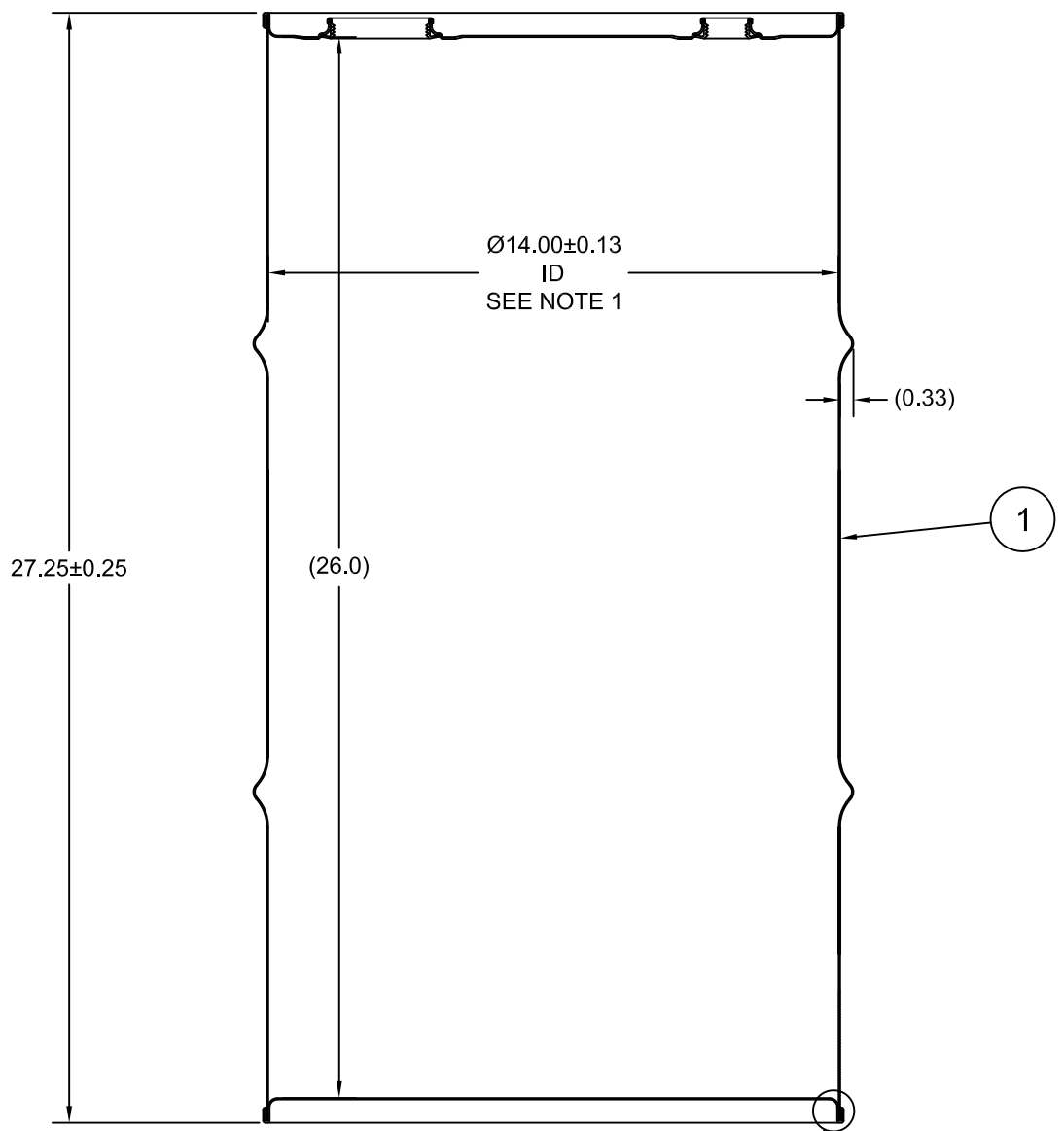
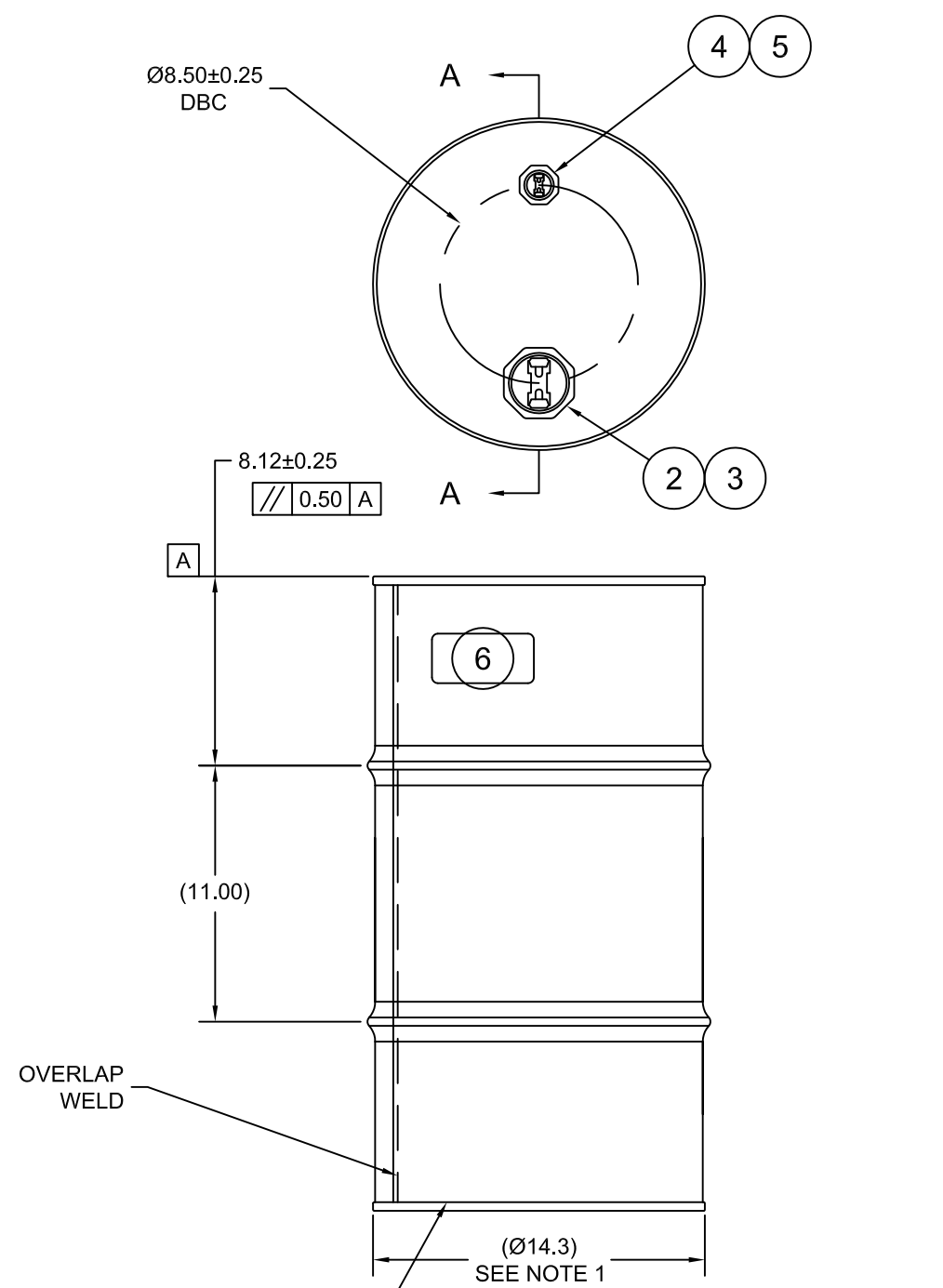

NOTES:

1. TO DETERMINE GREATER ACCURACY OF ANY DIAMETRIC DIMENSION, MEASURING OF CIRCUMFERENCE IS REQUIRED
2. CONSTRUCTION per 49 CFR §178.504 (b)

MATERIAL:

1. DRUM BODY AND COVER CRCQ CARBON STEEL PER ASTM A1008 AND ASTM A568 OR EQUIVALENT
2. MATERIAL THICKNESS 0.9mm (0.0319 - 0.0370, 20 GAUGE)

FINISH:

1. DRUM BODY EXTERIOR PAINTED BLACK (LQ10003)
COVER EXTERIOR PAINTED WHITE (LQ10020)

ITEM	P/N	DESCRIPTION	QTY
6		UN DURABLE LABEL	1
5	PT3000	PLUG 3/4 TS BUNA GASKET	1
4	FT3000	FLANGE 3/4 TS BUNA GASKET	1
3	PT2000	PLUG 2 TS BUNA BASKET	1
2	FT2000	FLANGE 2 TS BUNA GASKET	1
1		BODY/BOTTOM 16 GALLON DRUM 14.0 ID	1

UN NUMBER EMBOSSED ON BOTTOM OF DRUM
1/2" CHARACTERS READING:
UN/1A1/X1.4/250/YR
0.9 *
(YR = YEAR OF MANUFACTURE)

TARE WEIGHT:
17 lbs

THE USE OF INFORMATION CONTAINED HEREIN IS RESTRICTED FOR THE BENEFIT OF SKOLNIK INDUSTRIES ONLY. UNAUTHORIZED USE OR DISCLOSURE, COPYING OR OTHERWISE REPRODUCING (IN ANY MANNER) ANY PORTION OF THIS DRAWING WITHOUT PRIOR WRITTEN PERMISSION OF AN AUTHORIZED OFFICIAL OF SKOLNIK INDUSTRIES IS STRICTLY PROHIBITED.

MFG BR	DRW LJT	CHK JG
SLS DR	QA MD	
MG G. Petersen		
FILE CREATED IN AutoCAD 2002		

UNLESS STATED OTHERWISE
(DIMENSIONS IN PARENTHESIS ARE FOR REFERENCE ONLY!!!)
ALL DIMENSIONS ARE IN INCHES
DO NOT SCALE DRAWING
TOLERANCES:
FRACTIONS ±1/4
X° ± 3°
X.X ± 0.2
X.XX ± 0.10
X.XXX ± 0.030

SKOLNIK INDUSTRIES, INC.
4900 SOUTH KILBOURN AVENUE, CHICAGO, IL 60632

DESCRIPTION
16 GALLON TIGHT HEAD DRUM
0.9 - 0.9 - 0.9 CRCQ STEEL
1A1/X1.4/250

REL. DATE	PART NUM. / FILENAME	REV
-	CQ1603	A2