

100200

ECN # or INIT	REV	DESCRIPTION	DATE
OE-005	A1	REDRAWN TO AutoCAD	18-APR-2013

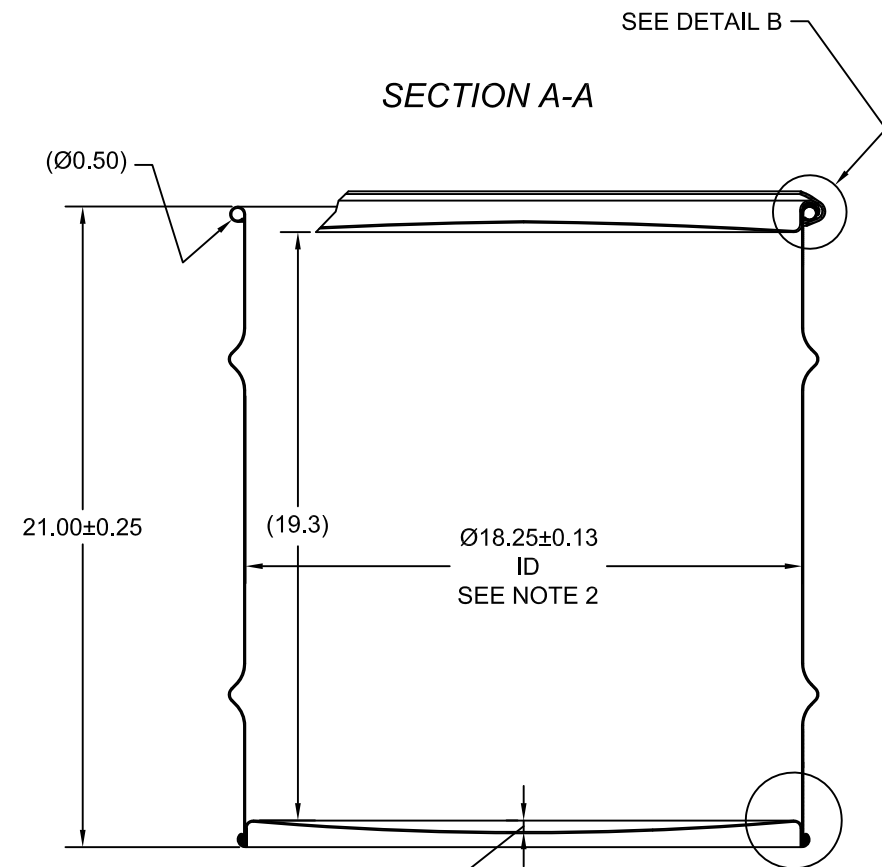
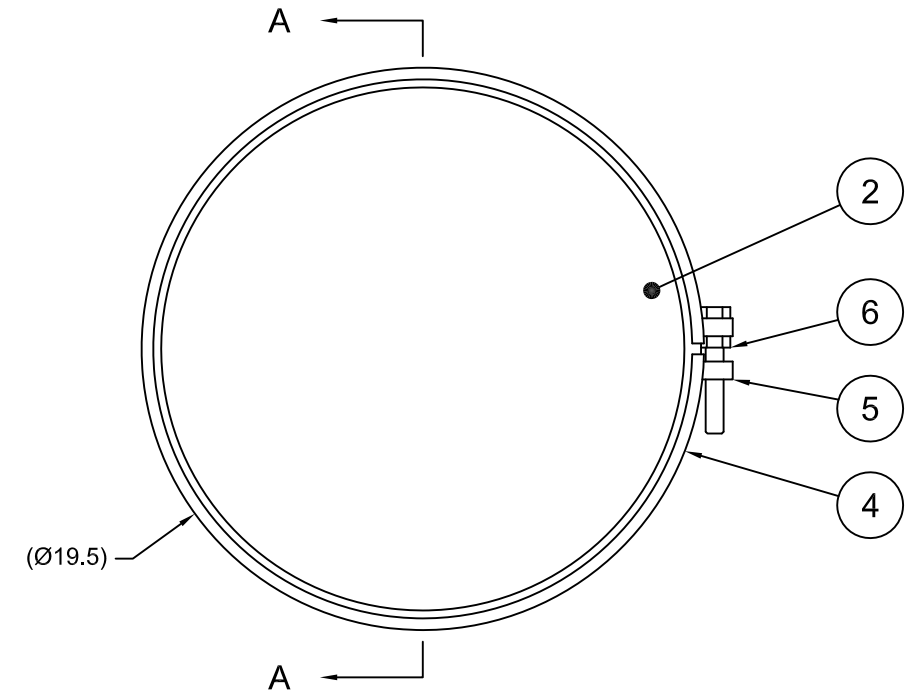

NOTES:

1. THIS DIMENSION REPRESENTS DRUM AFTER BEING PROPERLY ASSEMBLED AND CLOSED PER SKOLNIK CLOSING INSTRUCTIONS
2. TO DETERMINE GREATER ACCURACY OF ANY DIAMETRIC DIMENSION, MEASURING OF CIRCUMFERENCE IS REQUIRED
3. CONSTRUCTION per 49 CFR §178.504 (b)

MATERIAL:

1. CRCQ CARBON STEEL PER ASTM A1008 AND ASTM A568 OR EQUIVALENT
2. MATERIAL THICKNESS: 1.5mm (0.0543 - 0.0590, 16 GAUGE)
3. GASKET MAT'L PER ASTM D1056

FINISH:

1. DRUM EXTERIOR COVER PAINTED WHITE (LQ10020)
- BODY/BOTTOM PAINTED BLACK (LQ10003)

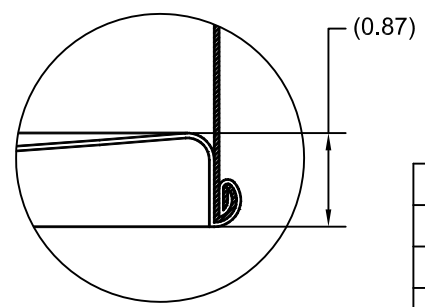
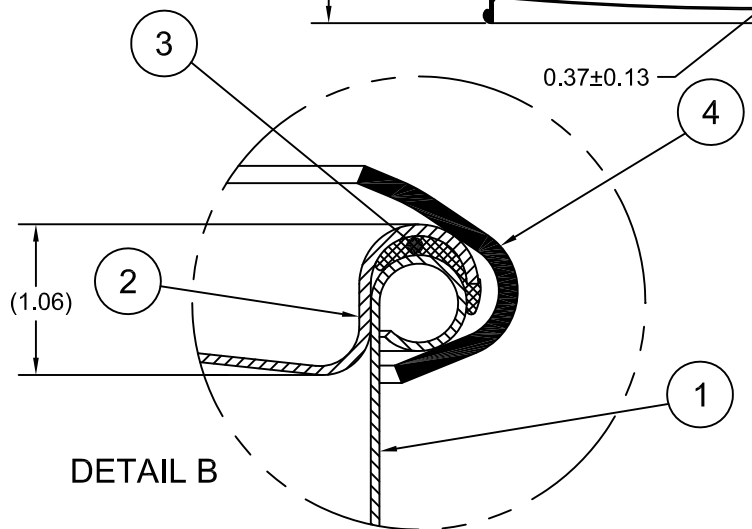
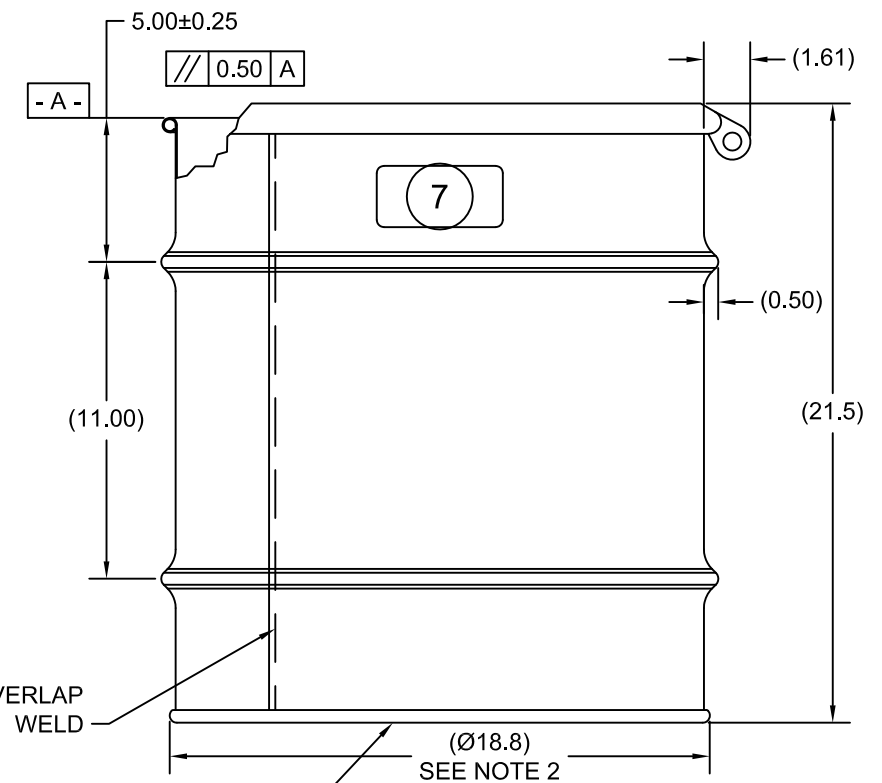

ITEM	ITEM	DESCRIPTION	QTY
7		UN DURABLE LABEL	1
6	NT5800	NUT 5/8-11UNC	1
5	BT5840	BOLT 5/8-11UNC X 4 LONG	1
4	RBH1812	BOLT RING (HP) 20-30G 12GA 5/8 LUG	1
3	GE2000	GASKET IN-COVER D EPDM	1
2	P1815	COVER 18.25 ID	1
1		BODY/BOTTOM 20 GALLON DRUM 18.25 ID	1

UN NUMBER EMBOSSED ON BOTTOM OF DRUM
 ½" CHARACTERS READING:
 UN/1A2/X195/S/YR
 UN/1A2/Y1.5/200/YR
 1.5*
 (YR = YEAR OF MANUFACTURE)

TARE WEIGHT:
34 lbs

THE USE OF INFORMATION CONTAINED HEREIN IS RESTRICTED FOR THE BENEFIT OF SKOLNIK INDUSTRIES ONLY. UNAUTHORIZED USE OR DISCLOSURE, COPYING OR OTHERWISE REPRODUCING (IN ANY MANNER) ANY PORTION OF THIS DRAWING WITHOUT PRIOR WRITTEN PERMISSION OF AN AUTHORIZED OFFICIAL OF SKOLNIK INDUSTRIES IS STRICTLY PROHIBITED.

MFG BR	DRW LJT	CHK JG
SLS DR	QA MD	
APR G. Petersen		
FILE CREATED IN AutoCAD 2002		

UNLESS STATED OTHERWISE
 (DIMENSIONS IN PARENTHESIS ARE FOR REFERENCE ONLY!!!)
 ALL DIMENSIONS ARE IN INCHES
 DO NOT SCALE DRAWING
 TOLERANCES:
 FRACTIONS ±1/4
 X° ± 3°
 X.X ± 0.2
 X.XX ± 0.10
 X.XXX ± 0.030

SKOLNIK INDUSTRIES, INC.
 4900 SOUTH KILBOURN AVENUE, CHICAGO, IL 60632

DESCRIPTION
 20 GALLON OPEN HEAD DRUM
 1.5 - 1.5 - 1.5 CRCQ STEEL
 1A2/X195/S & 1A2/Y1.5/200

REL. DATE	PART NUM. / FILENAME	REV
-	CQ2001	A1