

EQ3003

ECN # or INIT	REV	DESCRIPTION	DATE
OE-005	A1	REDRAWN TO AutoCAD	16-MAY-2013

SECTION A-A

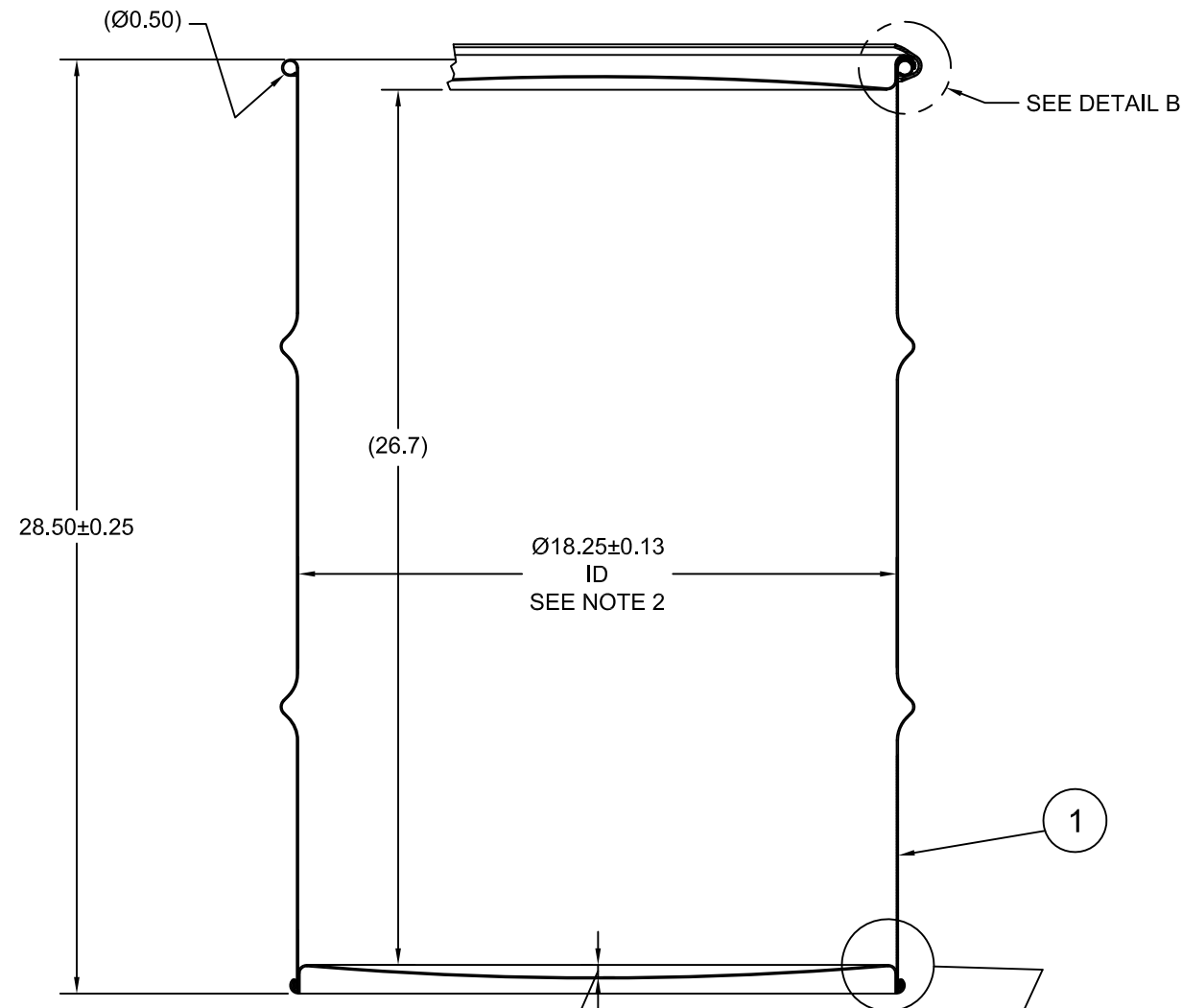
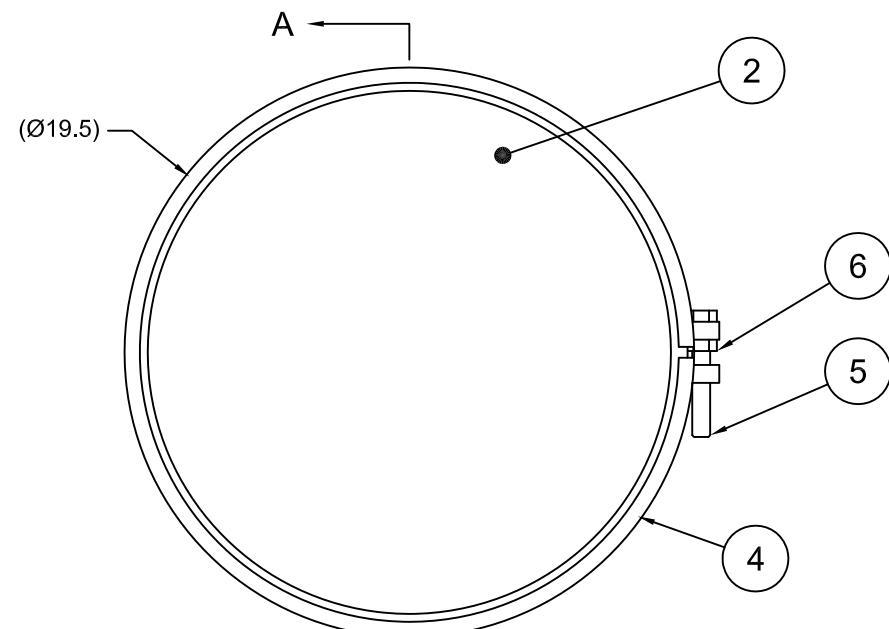

NOTES:

1. THESE DIMENSIONS REPRESENT DRUM AFTER BEING PROPERLY ASSEMBLED AND CLOSED PER SKOLNIK CLOSING INSTRUCTIONS
2. TO DETERMINE GREATER ACCURACY OF ANY DIAMETRIC DIMENSION, MEASURING OF CIRCUMFERENCE IS REQUIRED
3. CONSTRUCTION per 49 CFR §178.504 (b)

MATERIAL:

1. DRUM BODY AND COVER CRCQ CARBON STEEL PER ASTM A1008 AND ASTM A568 OR EQUIVALENT
2. MATERIAL THICKNESS: TOP/BOTTOM 1.2mm (0.0433 - 0.0480, 18 GAUGE), BODY 0.9mm (0.0319 - 0.0370, 20 GAUGE)
3. GASKET MAT'L PER ASTM D1056

FINISH:

1. BODY/BOTTOM EXTERIOR PAINTED BLACK (LQ10003)
COVER EXTERIOR PAINTED WHITE (LQ10020)

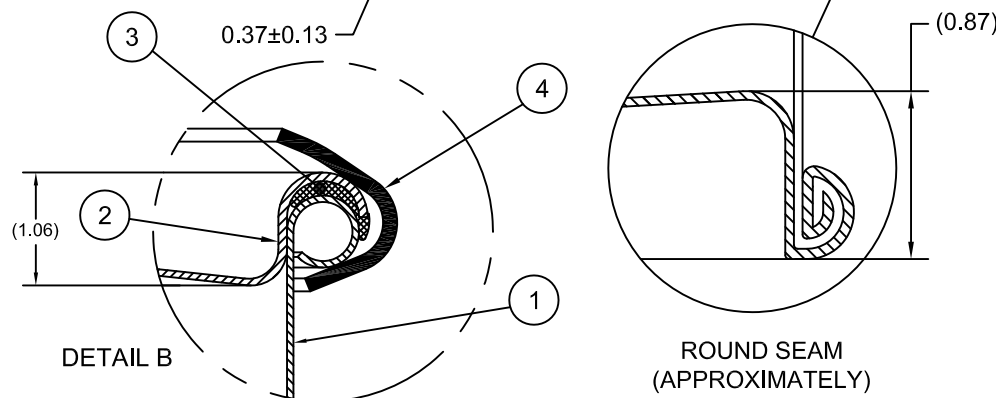
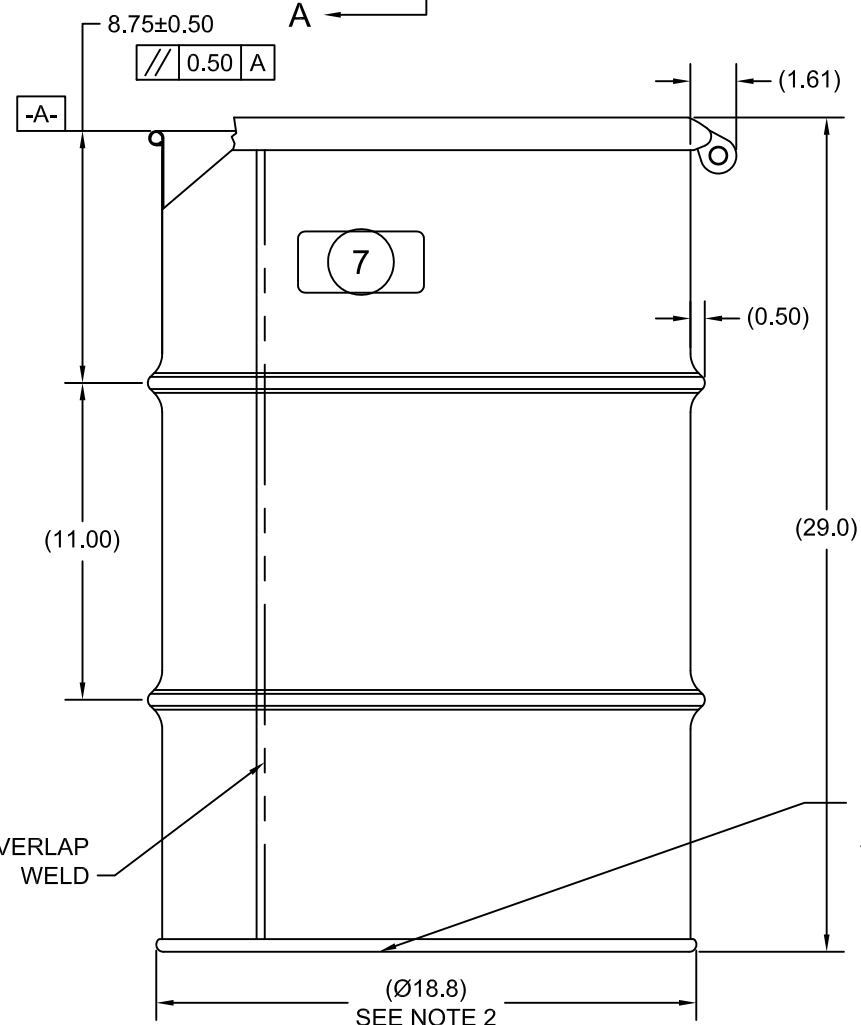

ITEM	P/N	DESCRIPTION	QTY
7		UN DURABLE LABEL	1
6	NT5800	5/8-11UNC HEX JAM NUT	1
5	BT5840	5/8-11UNC X 4in LONG HEX HEAD BOLT	1
4	RBH1812	BOLT RING 20-30G 12 GA 5/8 LUG	1
3	GE2000	GASKET EPDM IN-COVER D	1
2	P1812	COVER, Ø18.25 DRUM, CRCQ STEEL	1
1		30 GALLON DRUM BODY AND BOTTOM	1

UN NUMBER EMBOSSED ON BOTTOM OF DRUM
 ½" CHARACTERS READING:
 UN/1A2/X235/S/YR
 UN/1A2/Y1.8/150/YR
 1.2 - 0.9 - 1.2 *

(YR = YEAR OF MANUFACTURE)

TARE WEIGHT:
30 lbs

THE USE OF INFORMATION CONTAINED HEREIN IS RESTRICTED FOR THE BENEFIT OF SKOLNIK INDUSTRIES ONLY. UNAUTHORIZED USE OR DISCLOSURE, COPYING OR OTHERWISE REPRODUCING (IN ANY MANNER) ANY PORTION OF THIS DRAWING WITHOUT PRIOR WRITTEN PERMISSION OF AN AUTHORIZED OFFICIAL OF SKOLNIK INDUSTRIES IS STRICTLY PROHIBITED.

MFG BR	DRW LJT	CHK JG
SLS DR	QA MD	
APR G. Petersen		
FILE CREATED IN AutoCAD 2002	3 RD	

UNLESS STATED OTHERWISE

(DIMENSIONS IN PARENTHESIS ARE FOR REFERENCE ONLY!!!)

ALL DIMENSIONS ARE IN INCHES
DO NOT SCALE DRAWING

TOLERANCES:
 FRACTIONS ±1/4
 X° ± 3°
 X.X ± 0.2
 X.XX ± 0.10
 X.XXX ± 0.030

SKOLNIK INDUSTRIES, INC.
 4900 SOUTH KILBOURN AVENUE, CHICAGO, IL 60632

DESCRIPTION
 30 GALLON OPEN HEAD DRUM
 1.2 - 0.9 - 1.2 CRCQ
 1A2/X235/S & 1A2/Y1.8/150

REL. DATE	PART NUM. / FILENAME	REV
-	CQ3003	A1