

CQ3013

ECN # or INIT	REV	DESCRIPTION	DATE
OE-005	A1	REDRAWN TO AutoCAD	06-DEC-2012
13-002	B	LIQUID RATING WAS X1.2	01-APR-2013

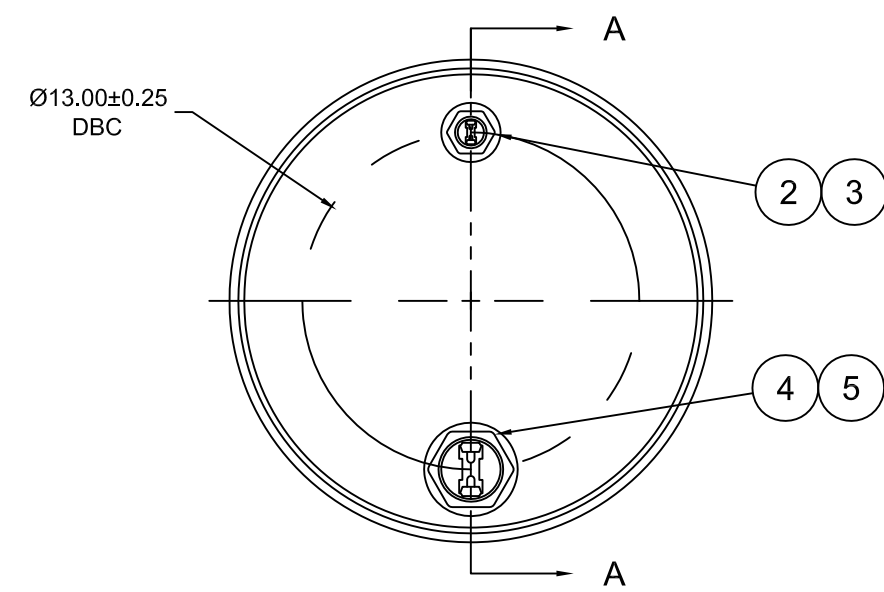

SECTION A-A
(SHOWN W/ PLUGS REMOVED)

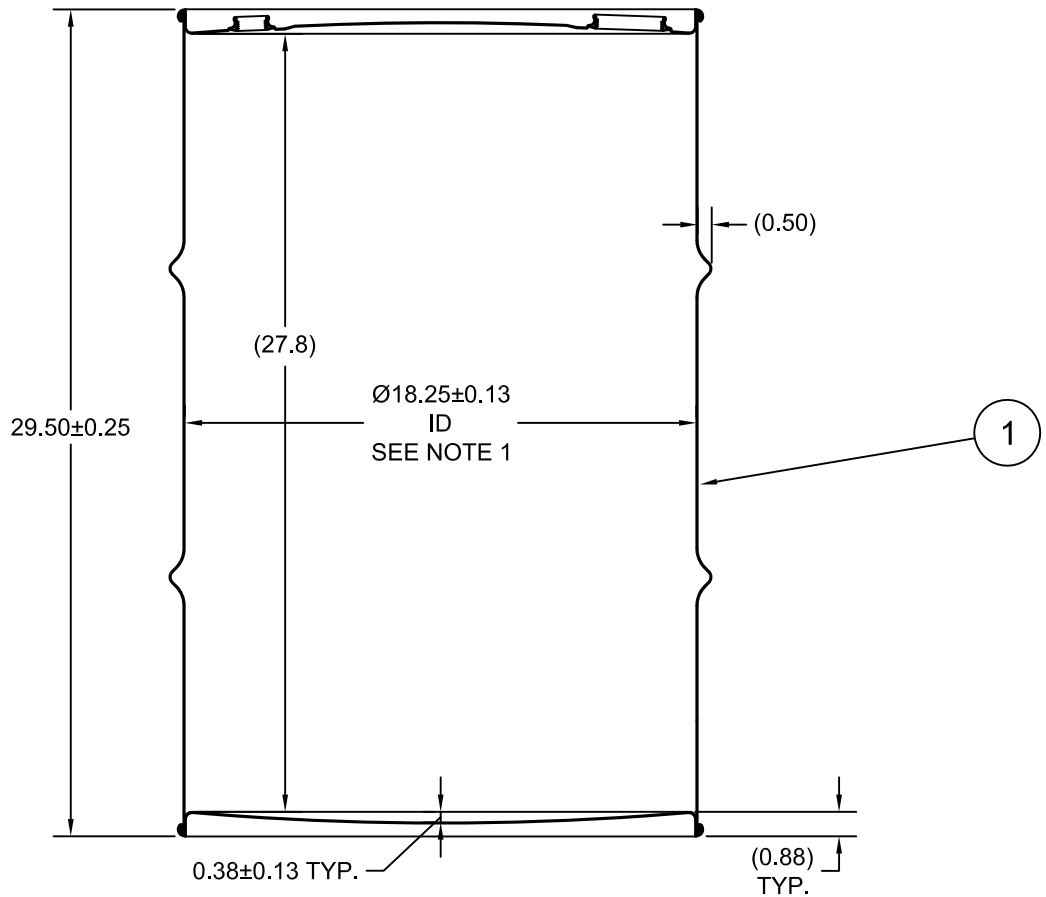

NOTES:

1. TO DETERMINE GREATER ACCURACY OF ANY DIAMETRIC DIMENSION, MEASURING OF CIRCUMFERENCE IS REQUIRED
2. CONSTRUCTION per 49 CFR §178.504 (b)

MATERIAL:

1. DRUM BODY AND COVER CRCQ CARBON STEEL PER ASTM A1008 OR ASTM A568 OR EQUIVALENT
2. MATERIAL THICKNESS: TOP/BOTTOM 1.5mm (0.0543 - 0.0590, 16 GAUGE), BODY 0.9mm (0.0319 - 0.0370, 20 GAUGE)

FINISH:

1. DRUM BODY/BOTTOM EXTERIOR PAINTED BLACK (LQ10003)
TOP EXTERIOR PAINTED WHITE (LQ10020)

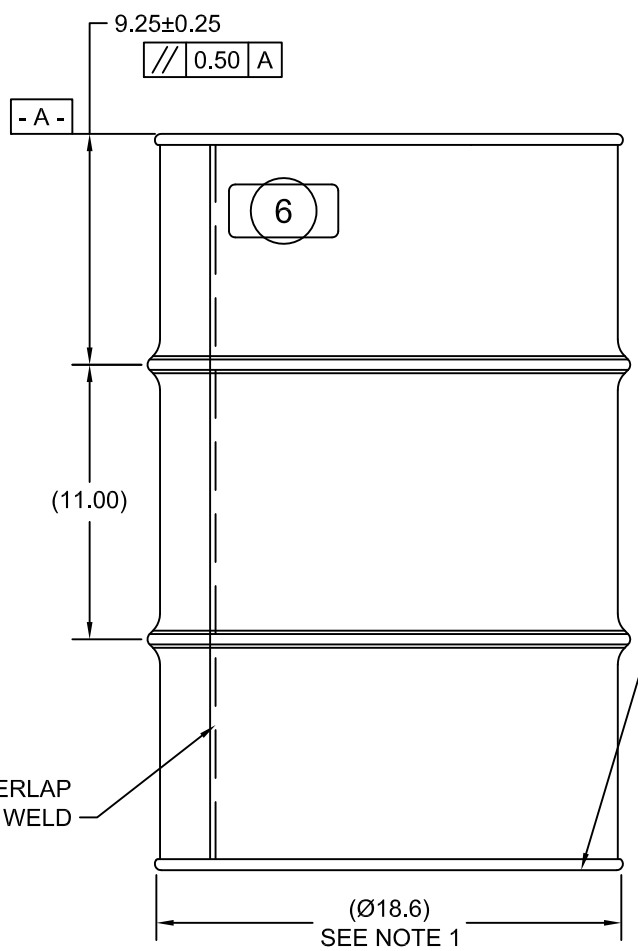

UN NUMBER EMBOSSED ON BOTTOM OF DRUM
 ½" CHARACTERS READING:
 UN/1A1/X1.8/300/YR
 1.5 - 0.9 - 1.5 *
 (YR = YEAR OF MANUFACTURE)

TARE WEIGHT:
31 lbs

ITEM	P/N	DESCRIPTION	QTY
6		UN DURABLE LABEL	1
5	PT2000	PLUG 2 TS BUNA GASKET	1
4	FT2000	FLANGE 2 TS BUNA GASKET	1
3	PT3000	PLUG 3/4 TS BUNA GASKET	1
2	FT3000	FLANGE 3/4 TS BUNA GASKET	1
1		30 GALLON TH DRUM	1

THE USE OF INFORMATION CONTAINED HEREIN IS RESTRICTED FOR THE BENEFIT OF SKOLNIK INDUSTRIES ONLY. UNAUTHORIZED USE OR DISCLOSURE, COPYING OR OTHERWISE REPRODUCING (IN ANY MANNER) ANY PORTION OF THIS DRAWING WITHOUT PRIOR WRITTEN PERMISSION OF AN AUTHORIZED OFFICIAL OF SKOLNIK INDUSTRIES IS STRICTLY PROHIBITED.

MFG BR	DRW LJT	CHK JG
SLS DR	QA MD	
APR G. Petersen		
FILE CREATED IN AutoCAD 2002		

UNLESS STATED OTHERWISE
 (DIMENSIONS IN PARENTHESIS ARE FOR REFERENCE ONLY!!!)
 ALL DIMENSIONS ARE IN INCHES
 DO NOT SCALE DRAWING
 TOLERANCES:
 FRACTIONS ±1/4
 X° ± 3°
 X.X ± 0.2
 X.XX ± 0.10
 X.XXX ± 0.030

SKOLNIK INDUSTRIES, INC.
 4900 SOUTH KILBOURN AVENUE, CHICAGO, IL 60632

DESCRIPTION
 30 GALLON TIGHT HEAD DRUM
 1.5 - 0.9 - 1.5 CRCQ STEEL
 1A1/X1.8/300

REL. DATE	PART NUM. / FILENAME	REV
-	CQ3013	B

BEST PRINTED ON B-SIZE PAPER