

CQ5504Q

ECN # or INIT	REV	DESCRIPTION	DATE
OE-005	A1	REDRAWN TO AutoCAD	16-APR-2013
17-001	A2	REMOVED LIQUID RATING	03-APR-2017

SECTION A-A

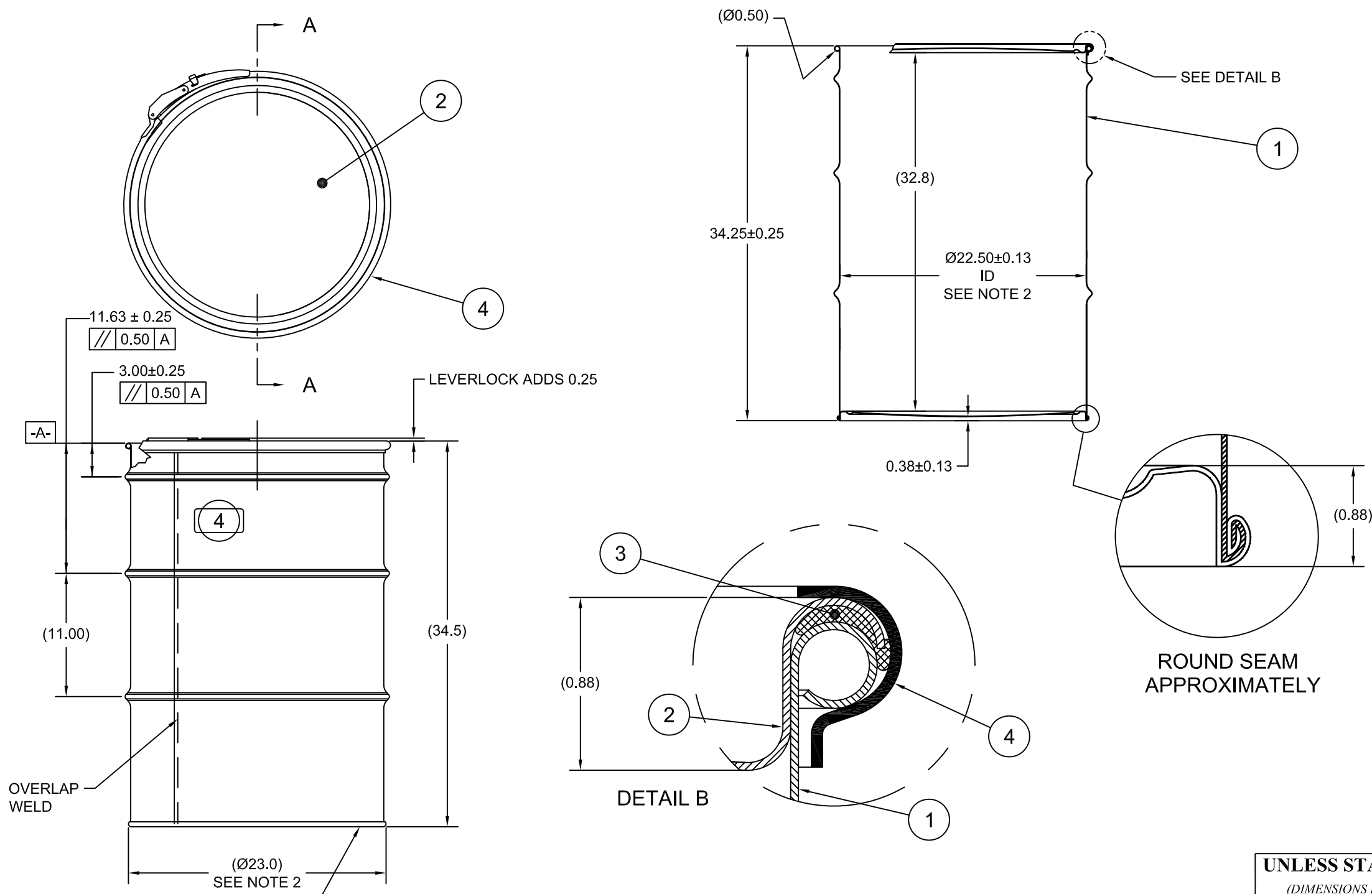

NOTES:

1. THESE DIMENSIONS REPRESENT DRUM AFTER BEING PROPERLY ASSEMBLED AND CLOSED PER SKOLNIK CLOSING INSTRUCTIONS
2. TO DETERMINE GREATER ACCURACY OF ANY DIAMETRIC DIMENSION, MEASURING OF CIRCUMFERENCE IS REQUIRED
3. CONSTRUCTION per 49 CFR §178.504 (b)

MATERIAL:

1. DRUM BODY AND COVER CRCQ CARBON STEEL PER ASTM A1008 AND ASTM A568
2. MATERIAL THICKNESS: COVER 1.2mm (0.0433 - 0.0480, 18 GAUGE), BODY/BOTTOM 0.9mm (0.0319 - 0.0370, 20 GAUGE)
3. GASKET MAT'L PER ASTM D1056

FINISH:

1. BODY/BOTTOM EXTERIOR PAINTED BLACK (LQ10003)
COVER EXTERIOR PAINTED WHITE (LQ10020)

ITEM	P/N	DESCRIPTION	QTY
5		UN DURABLE LABEL	1
4	RQ5513	55 GALLON QUICK LEVERLOCK RING	1
3	GE5500	GASKET IN-COVER D EPDM	1
2	P2212	COVER 22.5 ID	1
1		BODY/BOTTOM 55 GALLON DRUM 22.5 ID	1

BEST PRINTED ON B-SIZE PAPER

UN NUMBER EMBOSSED ON BOTTOM OF DRUM
 ½" CHARACTERS READING:
 UN/1A2/Y425/S/YR
 1.2 - 0.9 - 0.9 *
 (YR = YEAR OF MANUFACTURE)

TARE WEIGHT:
38 lbs

THE USE OF INFORMATION CONTAINED HEREIN IS RESTRICTED FOR THE BENEFIT OF SKOLNIK INDUSTRIES ONLY. UNAUTHORIZED USE OR DISCLOSURE, COPYING OR OTHERWISE REPRODUCING (IN ANY MANNER) ANY PORTION OF THIS DRAWING WITHOUT PRIOR WRITTEN PERMISSION OF AN AUTHORIZED OFFICIAL OF SKOLNIK INDUSTRIES IS STRICTLY PROHIBITED.

APPROVAL
ON FILE

FILE CREATED IN
AutoCAD

UNLESS STATED OTHERWISE

(DIMENSIONS IN PARENTHESIS ARE FOR REFERENCE ONLY!!!)
 ALL DIMENSIONS ARE IN INCHES
 DO NOT SCALE DRAWING
 TOLERANCES:
 FRACTIONS ±1/4
 X° ± 3°
 X.X ± 0.2
 X.XX ± 0.10
 X.XXX ± 0.030

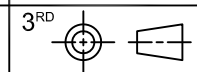

SKOLNIK INDUSTRIES, INC.
 4900 SOUTH KILBOURN AVENUE, CHICAGO, IL 60632

DESCRIPTION		
55 GALLON OPEN HEAD DRUM 1.2 - 0.9 - 0.9 CRCQ 1A2/Y425/S		
REL. DATE	PART NUM. / FILENAME	REV
-	CQ5504Q	A2