

Z003WH

ECN # or INIT	REV	DESCRIPTION	DATE
OE-005	A1	REDRAWN TO AutoCAD	18-APR-2013
OE-018	A2	WAS MULTI-LINGUAL SALVAGE LOGO	17-OCT-2016

SECTION A-A

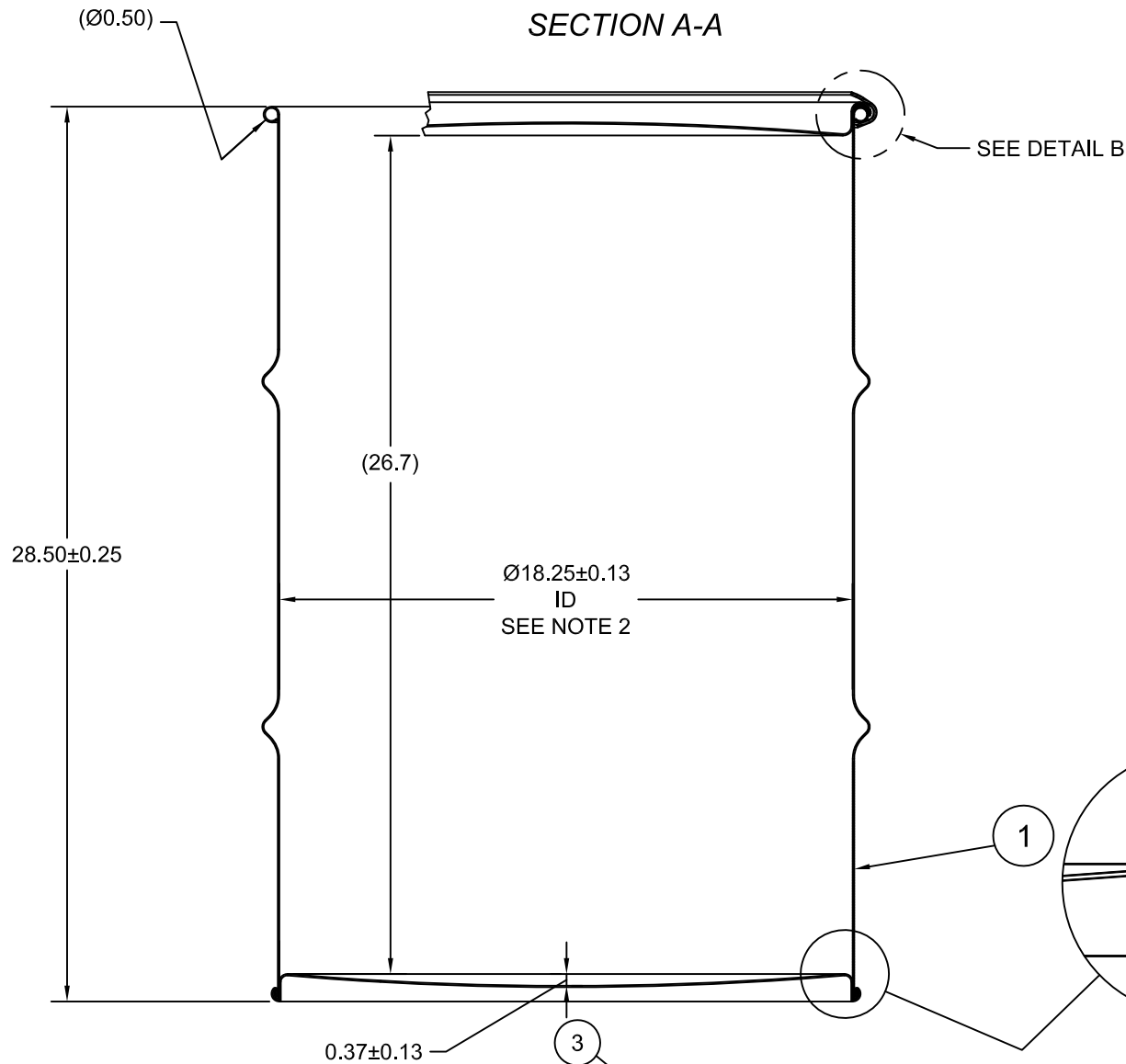
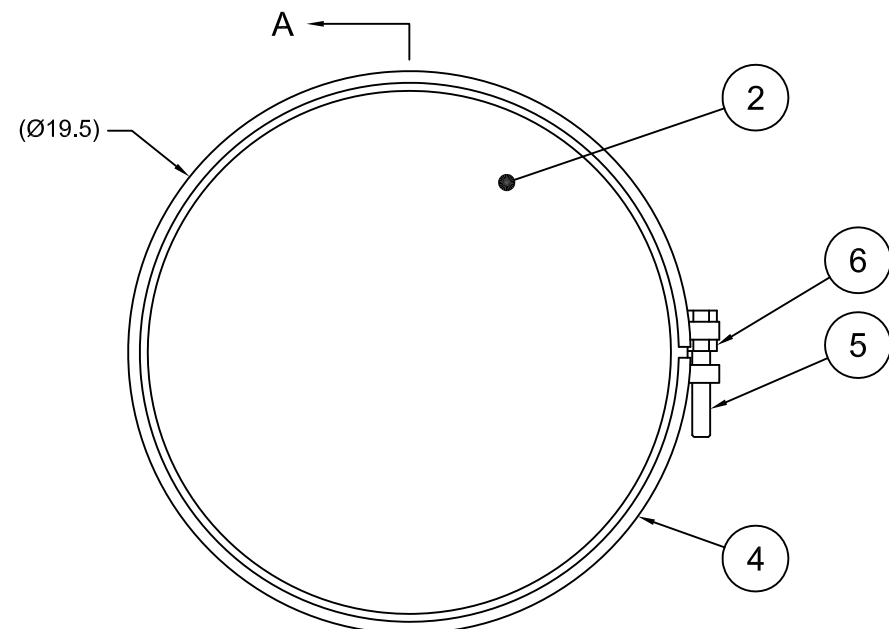

NOTES:

1. THESE DIMENSIONS REPRESENT DRUM AFTER BEING PROPERLY ASSEMBLED AND CLOSED PER SKOLNIK CLOSING INSTRUCTIONS
2. TO DETERMINE GREATER ACCURACY OF ANY DIAMETRIC DIMENSION, MEASURING OF CIRCUMFERENCE IS REQUIRED
3. CONSTRUCTION per 49 CFR §178.504 (b)

MATERIAL:

1. DRUM BODY AND COVER CRCQ CARBON STEEL PER ASTM A1008 AND ASTM A568
2. MATERIAL THICKNESS: 0.9mm (0.0319 - 0.0370, 20 GAUGE)
3. GASKET MAT'L PER ASTM D1056

FINISH:

1. BODY/BOTTOM EXTERIOR PAINTED YELLOW (LQ10024)
COVER EXTERIOR PAINTED RED (LQ10017)

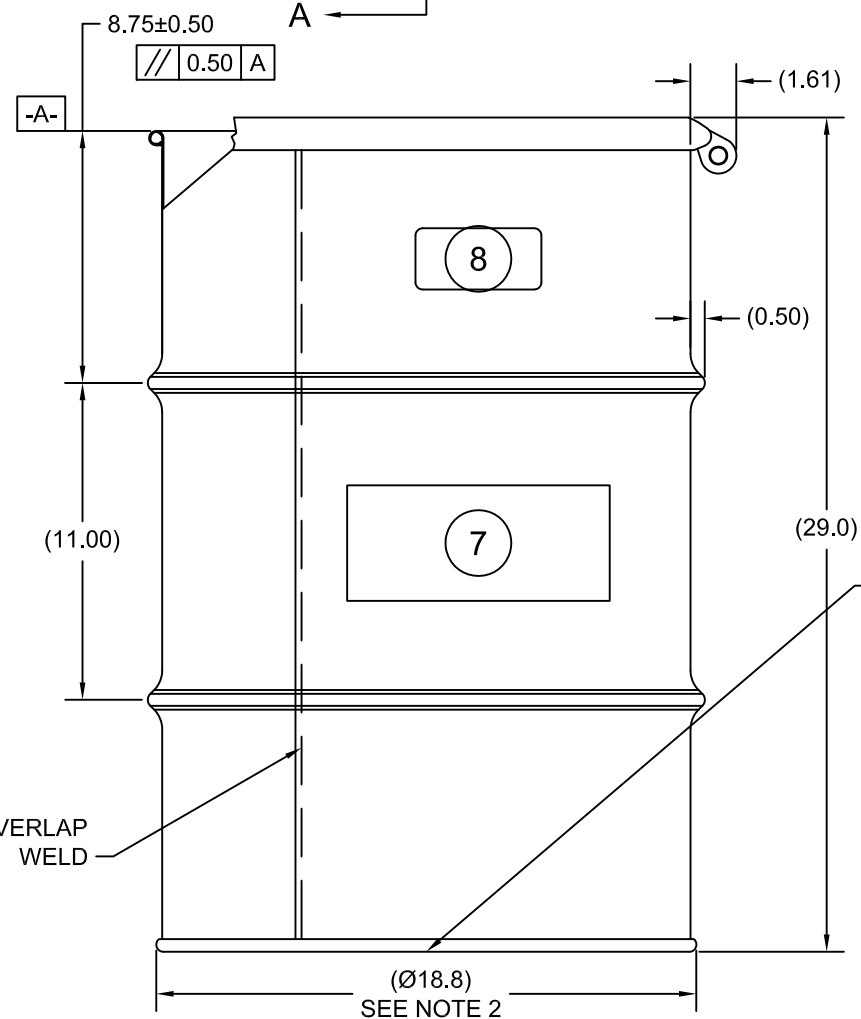

UN NUMBER EMBOSSED ON BOTTOM OF DRUM
 ½" CHARACTERS READING:
 UN/1A2/X200/S/YR
 UN/1A2/Y1.5/150/YR
 0.9 *
 (YR = YEAR OF MANUFACTURE)

TARE WEIGHT:
26 lbs

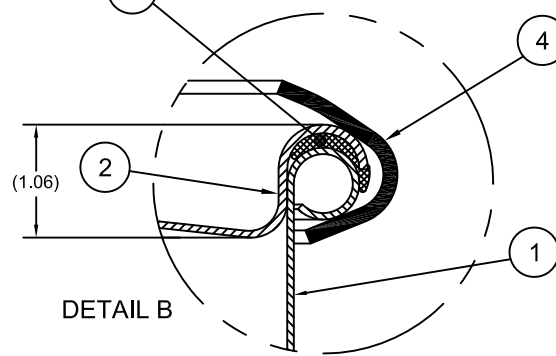
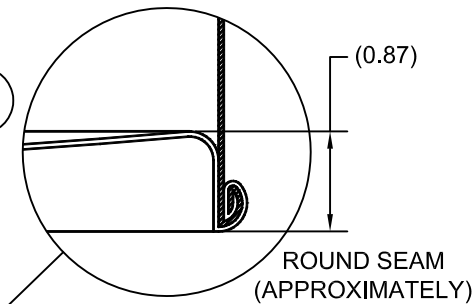

ITEM	P/N	DESCRIPTION	QTY
8		UN DURABLE LABEL	1
7	LS1000	LOGO SALVAGE DRUM	1
6	NT5800	5/8-11UNC HEX JAM NUT	1
5	BT5840	5/8-11UNC X 4 LONG HEX HEAD BOLT	1
4	RBH1812	BOLT RING 20-30G 12 GA 5/8 LUG	1
3	GE2000	GASKET EPDM IN-COVER D	1
2	P1809	COVER, Ø18.25 DRUM, CRCQ STEEL	1
1		30 GALLON DRUM BODY AND BOTTOM	1

UNLESS STATED OTHERWISE

(DIMENSIONS IN PARENTHESIS ARE FOR REFERENCE ONLY!!!)

ALL DIMENSIONS ARE IN INCHES
DO NOT SCALE DRAWING

TOLERANCES:
 FRACTIONS ±1/4
 X° ± 3°
 X.X ± 0.2
 X.XX ± 0.10
 X.XXX ± 0.030

APPROVAL
ON FILE

FILE CREATED IN
AutoCAD



THE USE OF INFORMATION CONTAINED HEREIN IS RESTRICTED FOR THE BENEFIT OF SKOLNIK INDUSTRIES ONLY. UNAUTHORIZED USE OR DISCLOSURE, COPYING OR OTHERWISE REPRODUCING (IN ANY MANNER) ANY PORTION OF THIS DRAWING WITHOUT PRIOR WRITTEN PERMISSION OF AN AUTHORIZED OFFICIAL OF SKOLNIK INDUSTRIES IS STRICTLY PROHIBITED.

SKOLNIK INDUSTRIES, INC.
4900 SOUTH KILBOURN AVENUE, CHICAGO, IL 60632

DESCRIPTION
30 GALLON OPEN HEAD DRUM
0.9 - 0.9 - 0.9 CRCQ STEEL
1A2/X200/S & 1A2/Y1.5/150

REL. DATE	PART NUM. / FILENAME	REV
-	HM3002	A2