

HM5502

ECN # or INIT	REV	DESCRIPTION	DATE
LJT	A1	REDRAWN TO AutoCAD	15-FEB-2013
OE-018	A2	WAS MULTI-LINGUAL SALVAGE LOGO	18-OCT-2016

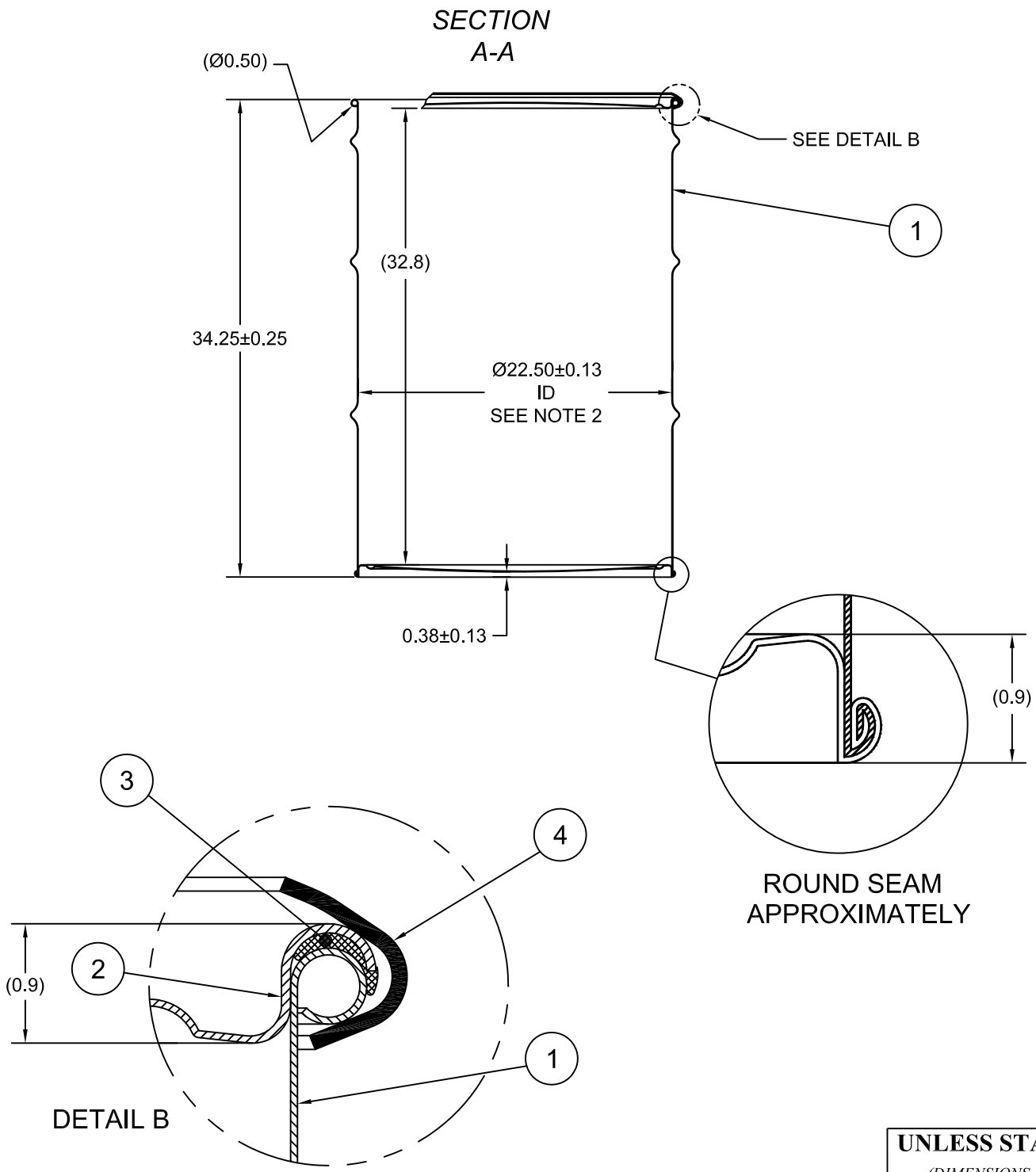
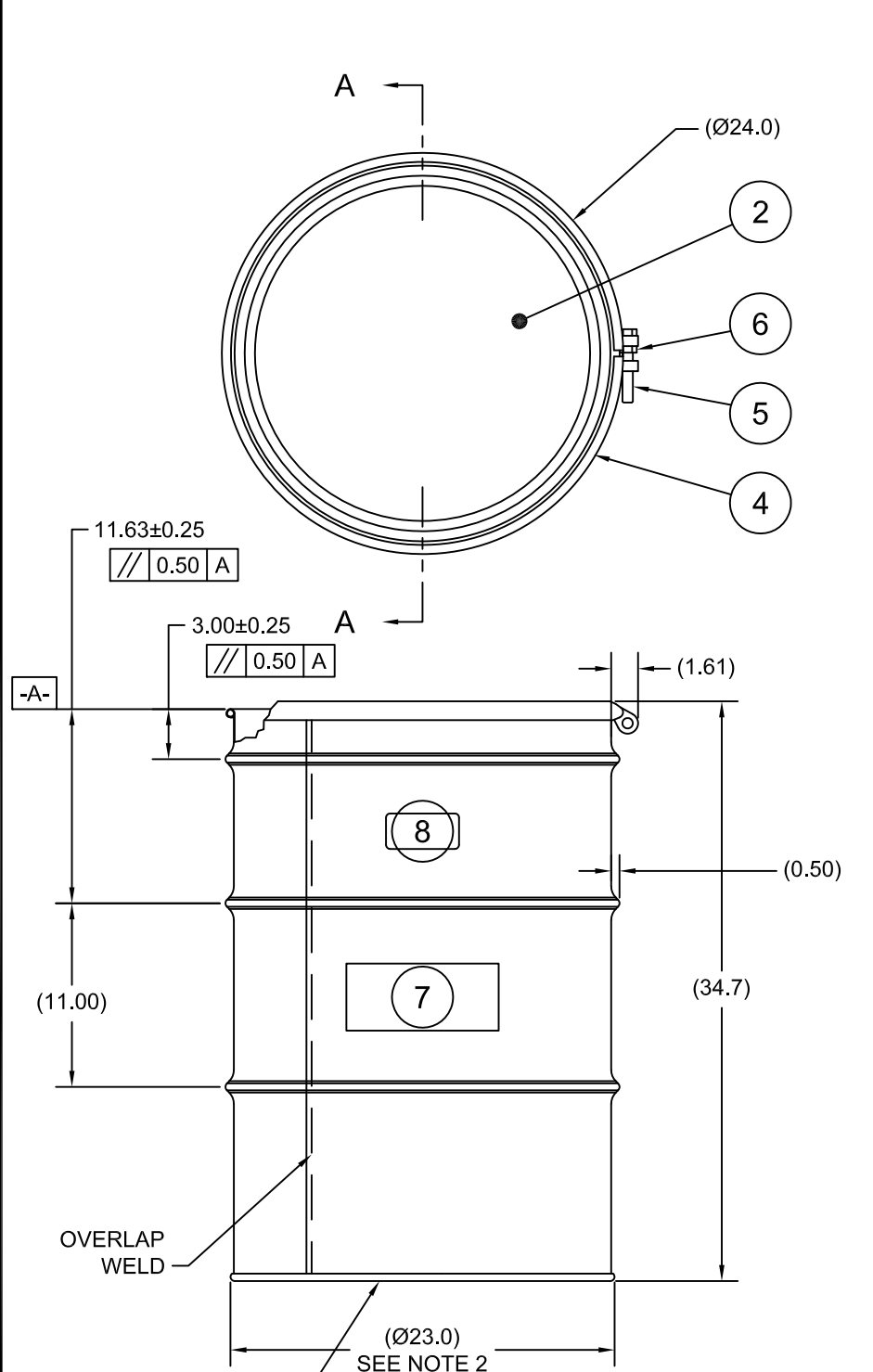

NOTES:

1. THESE DIMENSIONS REPRESENT DRUM AFTER BEING PROPERLY ASSEMBLED AND CLOSED PER SKOLNIK CLOSING INSTRUCTIONS
2. TO DETERMINE GREATER ACCURACY OF ANY DIAMETRIC DIMENSION, MEASURING OF CIRCUMFERENCE IS REQUIRED
3. CONSTRUCTION per 49 CFR §178.504 (b)

MATERIAL:

1. DRUM BODY AND COVER CRCQ CARBON STEEL PER ASTM A1008 AND ASTM A568
2. MATERIAL THICKNESS: COVER 1.5mm (0.0543 - 0.0590, 16 GAUGE), BODY/BOTTOM 1.2mm (0.0433 - 0.0480, 18 GAUGE)
3. GASKET MAT'L PER ASTM D1056

FINISH:

1. COVER EXTERIOR PAINTED RED (LQ10017)
- DRUM BODY/BOTTOM EXTERIOR PAINTED YELLOW (LQ10024)

ITEM	P/N	DESCRIPTION	QTY
8		UN DURABLE LABEL	1
7	LS1000	LOGO SALVAGE DRUM	1
6	NT5800	5/8-11UNC HEX JAM NUT	1
5	BT5840	5/8-11UNC X 4 LONG HEX HEAD BOLT	1
4	RBH2212	BOLT RING (HP) 55G 12GA 5/8 LUG	1
3	GE5500	GASKET IN-COVER D EPDM	1
2	P2215	COVER 22.5 ID	1
1		BODY/BOTTOM 55 GALLON DRUM 22.5 ID	1

UN NUMBER EMBOSSED ON BOTTOM OF DRUM
 1/2" CHARACTERS READING:
 UN/1A2/X400/S/YR
 UN/1A2/Y1.5/150/YR
 1.5 - 1.2 - 1.2 *
 (YR = YEAR OF MANUFACTURE)

TARE WEIGHT:
50 lbs

THE USE OF INFORMATION CONTAINED HEREIN IS RESTRICTED FOR THE BENEFIT OF SKOLNIK INDUSTRIES ONLY. UNAUTHORIZED USE OR DISCLOSURE, COPYING OR OTHERWISE REPRODUCING (IN ANY MANNER) ANY PORTION OF THIS DRAWING WITHOUT PRIOR WRITTEN PERMISSION OF AN AUTHORIZED OFFICIAL OF SKOLNIK INDUSTRIES IS STRICTLY PROHIBITED.

APPROVAL ON FILE

FILE CREATED IN AutoCAD

UNLESS STATED OTHERWISE

(DIMENSIONS IN PARENTHESIS ARE FOR REFERENCE ONLY!!!)
 ALL DIMENSIONS ARE IN INCHES
 DO NOT SCALE DRAWING
 TOLERANCES:
 FRACTIONS ±1/4
 X° ± 3°
 X.X ± 0.2
 X.XX ± 0.10
 X.XXX ± 0.030

SKOLNIK INDUSTRIES, INC.
 4900 SOUTH KILBOURN AVENUE, CHICAGO, IL 60632

DESCRIPTION
 55 GALLON OPEN HEAD DRUM
 1.5 - 1.2 - 1.2 CRCQ
 1A2/X400/S & 1A2/Y1.5/150

REL. DATE	PART NUM. / FILENAME	REV
-	HM5502	A2