

81581H

ECN # or INIT	REV	DESCRIPTION	DATE
	A	RELEASED	30-MAR-2007
LJT	A1	ADD'D TARE WEIGHT NOTE	08-FEB-2008
OE-001	A2	CLERICAL ERROR	08-APR-2013
OE-018	A3	WAS MULTI-LINGUAL SALVAGE LOGO	20-OCT-2016

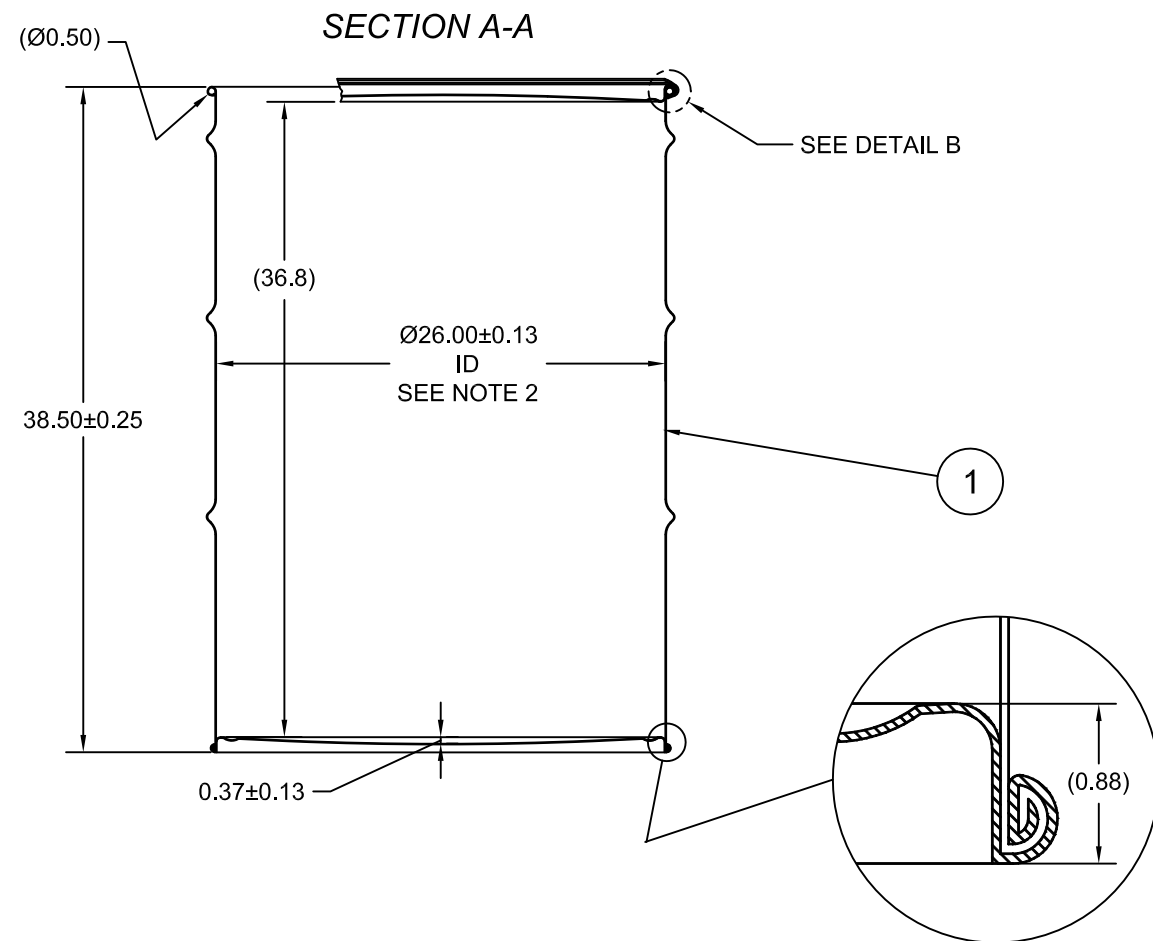
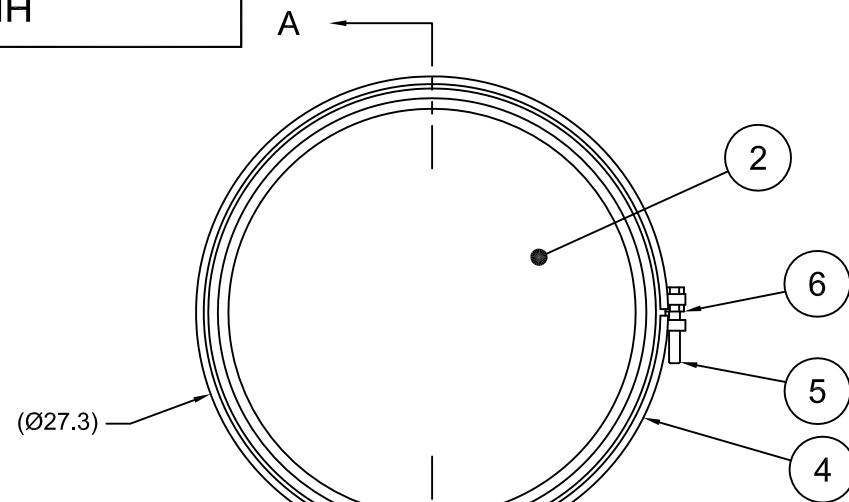

NOTES:

1. THESE DIMENSIONS REPRESENT DRUM AFTER BEING PROPERLY ASSEMBLED AND CLOSED PER SKOLNIK CLOSING INSTRUCTIONS
2. TO DETERMINE GREATER ACCURACY OF ANY DIAMETRIC DIMENSION, MEASURING OF CIRCUMFERENCE IS REQUIRED
3. CONSTRUCTION per 49 CFR §178.504 (b)

MATERIAL:

1. DRUM BODY AND COVER CRCQ CARBON STEEL PER ASTM A1008 AND ASTM A568
2. MATERIAL THICKNESS 1.2mm (0.0433 - 0.0480; 18 GAUGE).
3. GASKET MAT'L PER ASTM D1056

FINISH:

1. DRUM EXTERIOR PAINTED ALL YELLOW (LQ10024)

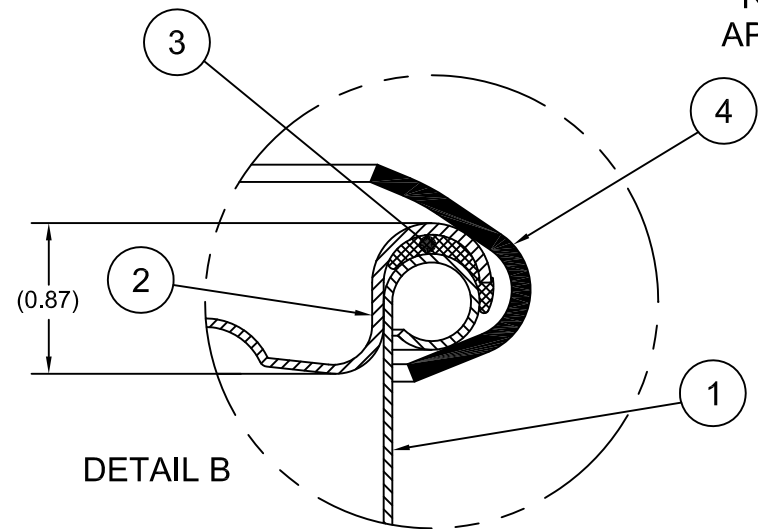
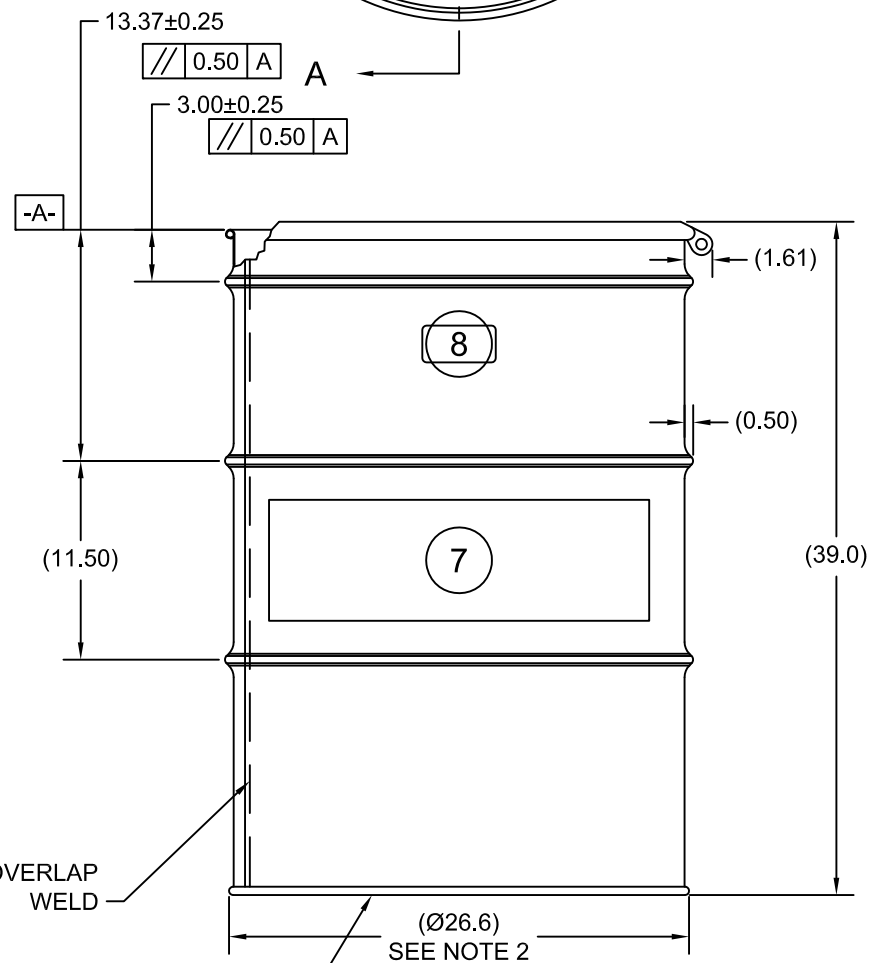

ROUND SEAM APPROXIMATELY

ITEM	P/N	DESCRIPTION	QTY
8		UN DURABLE LABEL	1
7	LS1000	LOGO SALVAGE DRUM	1
6	NT5800	5/8-11UNC HEX JAM NUT	1
5	BT5840	5/8-11UNC X 4in LONG HEX HEAD BOLT	1
4	RBH2612	BOLT RING (HP) 79-96G 12 GA 5/8 LUG	1
3	GE8500	GASKET EPDM IN-COVER D	1
2	P2612	COVER Ø26 ID, 18 GA	1
1		BODY/BOTTOM 85 GALLON DRUM Ø26 ID	1

UN NUMBER EMBOSSED ON BOTTOM OF DRUM
1/2" CHARACTERS

UN/1A2/X440/S/YR
UN/1A2T/Y320/S/YR
1.2 *

(YR = YEAR OF MANUFACTURE)

TARE WEIGHT:
63 lbs

UNLESS STATED OTHERWISE

(DIMENSIONS IN PARENTHESIS ARE FOR REFERENCE ONLY!!!)

ALL DIMENSIONS ARE IN INCHES
DO NOT SCALE DRAWING

TOLERANCES:

FRACTIONS ±1/4
X° ± 3°
X.X ± 0.2
X.XX ± 0.10
X.XXX ± 0.030

APPROVAL ON FILE

FILE CREATED IN
AutoCAD

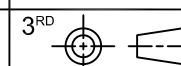

THE USE OF INFORMATION CONTAINED HEREIN IS RESTRICTED FOR THE BENEFIT OF SKOLNIK INDUSTRIES ONLY. UNAUTHORIZED USE OR DISCLOSURE, COPYING OR OTHERWISE REPRODUCING (IN ANY MANNER) ANY PORTION OF THIS DRAWING WITHOUT PRIOR WRITTEN PERMISSION OF AN AUTHORIZED OFFICIAL OF SKOLNIK INDUSTRIES IS STRICTLY PROHIBITED.

SKOLNIK INDUSTRIES, INC.
4900 SOUTH KILBOURN AVENUE, CHICAGO, IL 60632

DESCRIPTION
85 GALLON OPEN HEAD DRUM
1.2 - 1.2 - 1.2 CRCQ STEEL
1A2/X440/S & 1A2T/Y320/S

REL. DATE
30-MAR-2007

PART NUM. / FILENAME
HM8518

REV
A3