

ECN # or INIT	REV	DESCRIPTION	DATE
0E-005	A1	REDRAWN IN AutoCAD	09-MAR-2011
0E-001	A2	CLERICAL ERROR	16-APR-2013
0E-013	A3	REVISED HOOP PROFILE	22-APR-2013

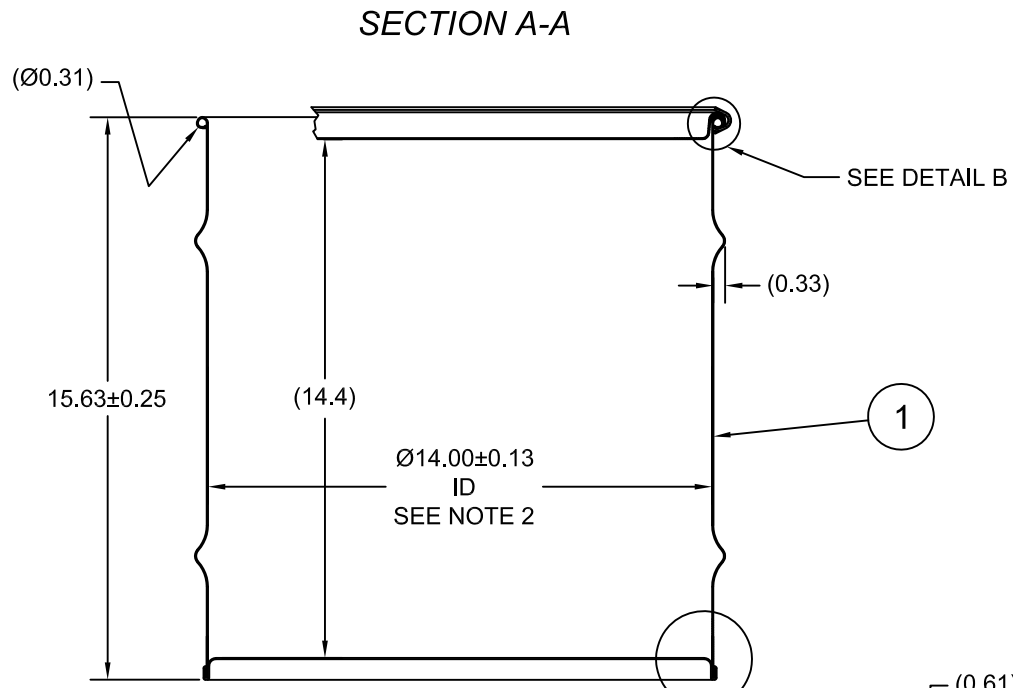
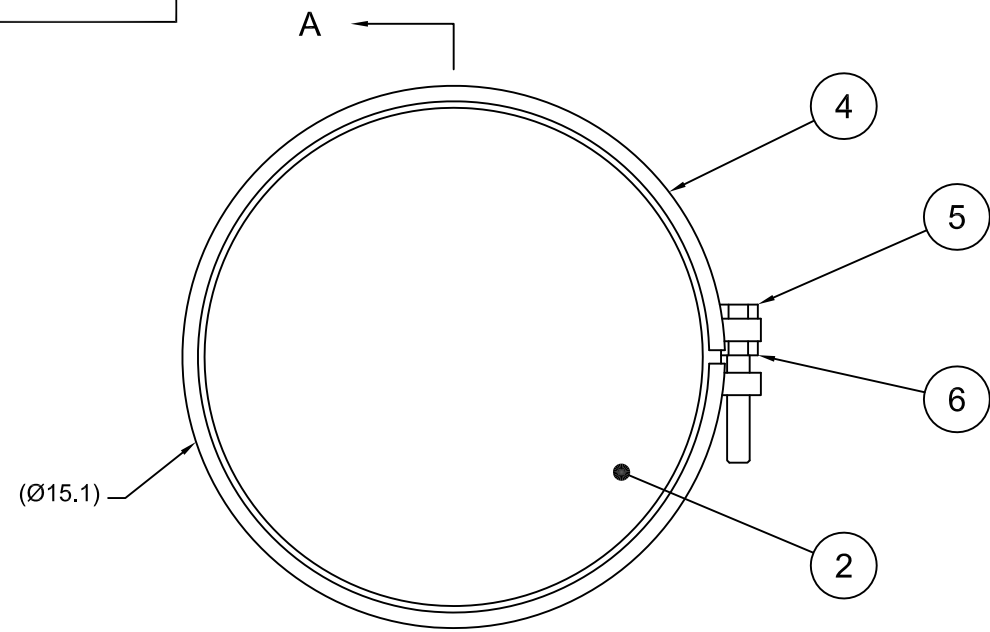

NOTES:

1. THESE DIMENSIONS REPRESENT DRUM AFTER BEING PROPERLY ASSEMBLED AND CLOSED PER SKOLNIK CLOSING INSTRUCTIONS.
2. TO DETERMINE GREATER ACCURACY OF ANY DIAMETRIC DIMENSION, MEASURING OF CIRCUMFERENCE IS REQUIRED
3. CONSTRUCTION per 49 CFR §178.504 (b)

MATERIAL:

1. 304SS PER ASTM A240 OR EQUIVALENT
2. MATERIAL THICKNESS: DRUM 0.9mm (0.0319 - 0.0370; 20 GAUGE)
3. GASKET MAT'L PER ASTM D1056

FINISH:

1. PASSIVATED INNER AND OUTER SURFACE OF BODY WELD SEAM

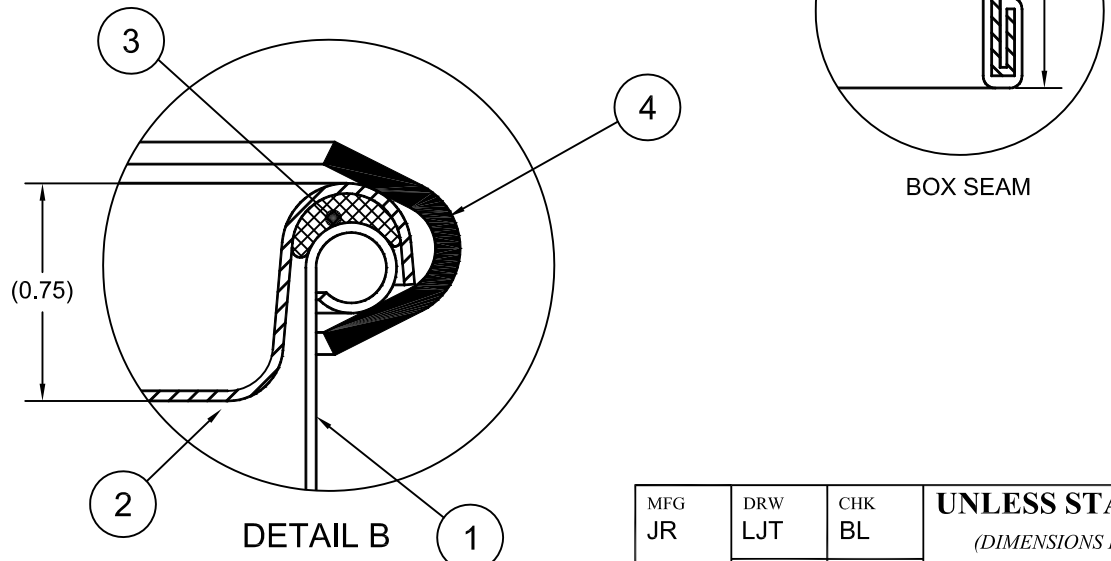
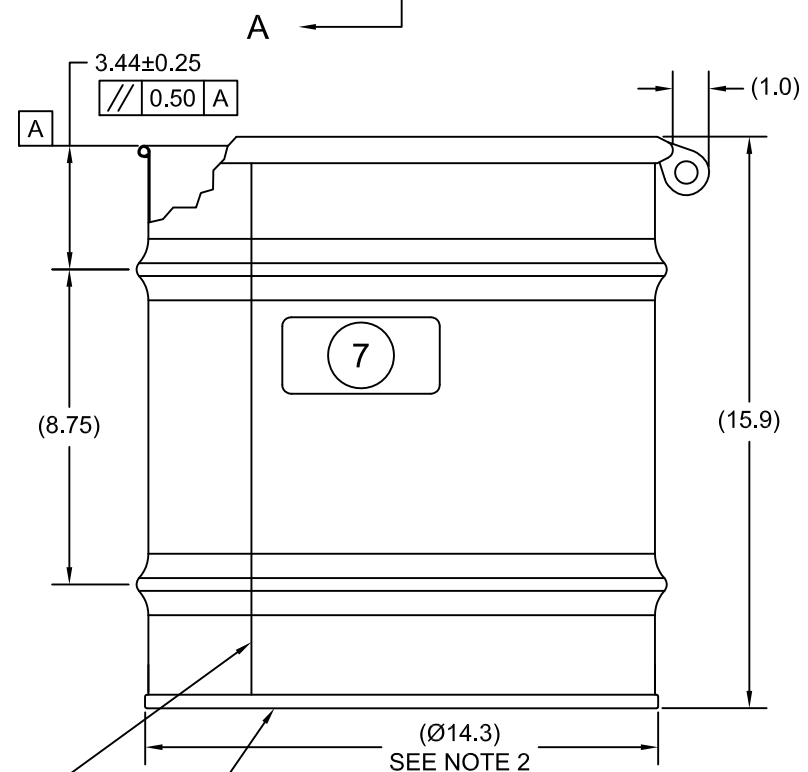

BOX SEAM

BUTT WELD

UN NUMBER EMBOSSED ON BOTTOM OF DRUM
 1/2" CHARACTERS READING:
 UN/1A2/X96/S/YR
 UN/1A2/Y1.8/150/YR
 0.9 * 304
 (YR = YEAR OF MANUFACTURE)

TARE WEIGHT:
13 lbs

THE USE OF INFORMATION CONTAINED HEREIN IS RESTRICTED FOR THE BENEFIT OF SKOLNIK INDUSTRIES ONLY. UNAUTHORIZED USE OR DISCLOSURE, COPYING OR OTHERWISE REPRODUCING (IN ANY MANNER) ANY PORTION OF THIS DRAWING WITHOUT PRIOR WRITTEN PERMISSION OF AN AUTHORIZED OFFICIAL OF SKOLNIK INDUSTRIES IS STRICTLY PROHIBITED.

MFG JR	DRW LJT	CHK BL
SLS DR	QA MD	
APR G. Petersen		
FILE CREATED IN AutoCAD 2002		

UNLESS STATED OTHERWISE
 (DIMENSIONS IN PARENTHESIS ARE FOR REFERENCE ONLY!!!)
 ALL DIMENSIONS ARE IN INCHES
 DO NOT SCALE DRAWING
 TOLERANCES:
 FRACTIONS $\pm 1/4$
 $X^\circ \pm 3^\circ$
 $X.X \pm 0.2$
 $X.XX \pm 0.10$
 $X.XXX \pm 0.030$

ITEM	P/N	DESCRIPTION	QTY
7		UN DURABLE LABEL	1
6	NT5800	5/8-11UNC HEX JAM NUT	1
5	BT5840	5/8-11UNC X 4in LONG HEX HEAD BOLT	1
4	RBH1413	BOLT RING (MOD A) 14 ID DRUM 13GA	1
3	GE0503-01	GASKET 3/8 DIA RD EPDM	1
2	P1409S	COVER 14 ID	1
1		BODY/BOTTOM 8 GALLON DRUM 14 ID	1

SKOLNIK INDUSTRIES, INC.
 4900 SOUTH KILBOURN AVENUE, CHICAGO, IL 60632

DESCRIPTION
 8 GALLON OPEN HEAD DRUM
 0.9 - 0.9 - 0.9 304SS
 1A2/X96/S & 1A2/Y1.8/150

REL. DATE: - PART NUM. / FILENAME: **ST0804** REV: **A3**