

ST1004

ECN # or INIT	REV	DESCRIPTION	DATE
	A1	REDRAWN IN AutoCAD	30-JUN-2009
OE-001	A2	CLERICAL ERROR	16-APR-2013
OE-013	A3	REVISED HOOP PROFILE	22-APR-2013

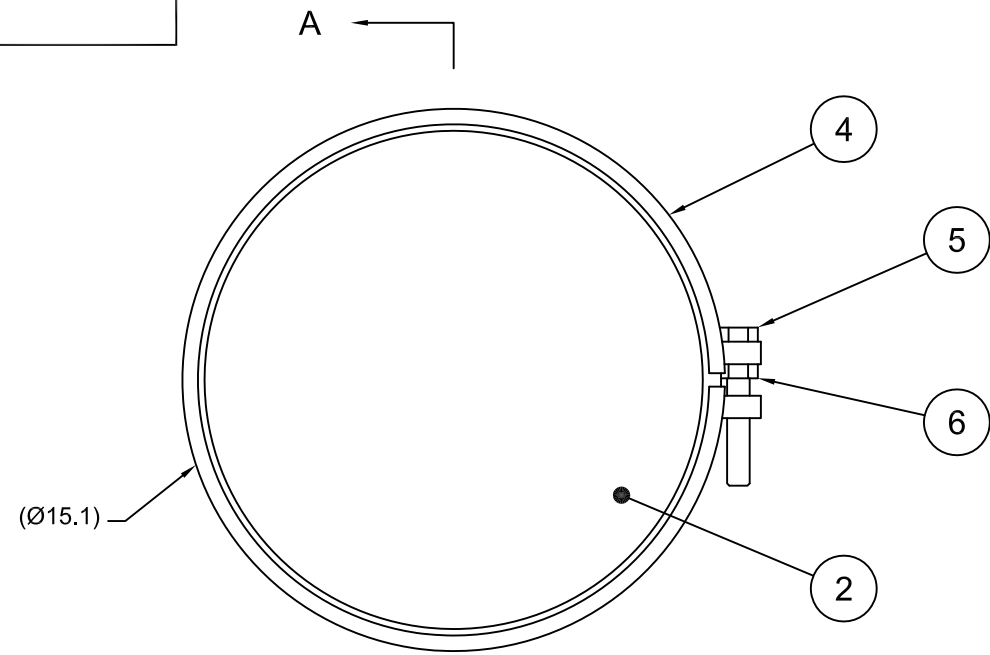

SECTION A-A

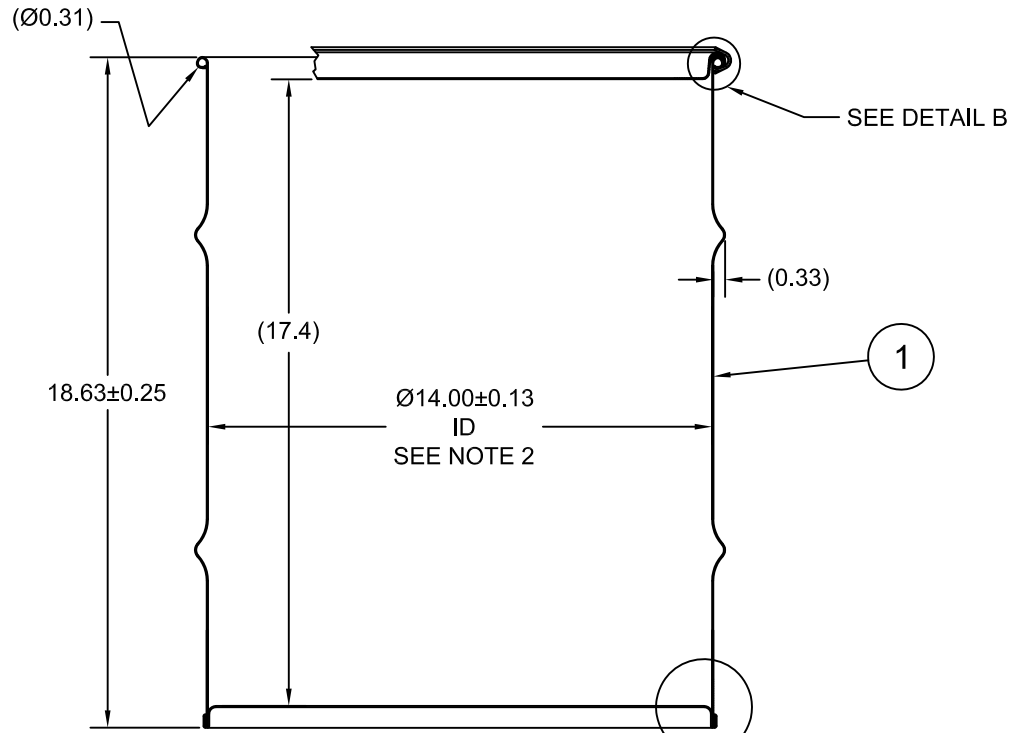

NOTES:

1. THESE DIMENSIONS REPRESENT DRUM AFTER BEING PROPERLY ASSEMBLED AND CLOSED PER SKOLNIK CLOSING INSTRUCTIONS.
2. TO DETERMINE GREATER ACCURACY OF ANY DIAMETRIC DIMENSION, MEASURING OF CIRCUMFERENCE IS REQUIRED
3. CONSTRUCTION per 49 CFR §178.504 (b)

MATERIAL:

1. 304SS PER ASTM A240 OR EQUIVALENT
2. MATERIAL THICKNESS: DRUM 0.9mm (0.0319 - 0.0370, 20 GAUGE)
3. GASKET MAT'L PER ASTM D1056

FINISH:

1. PASSIVATED INNER AND OUTER SURFACE OF BODY WELD SEAM

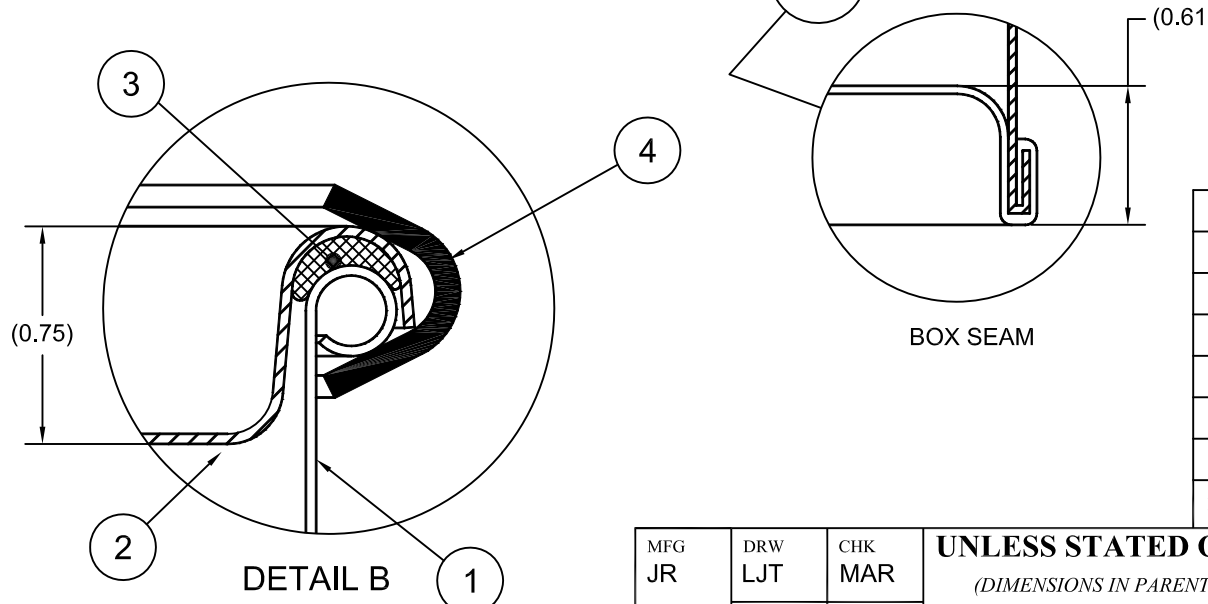
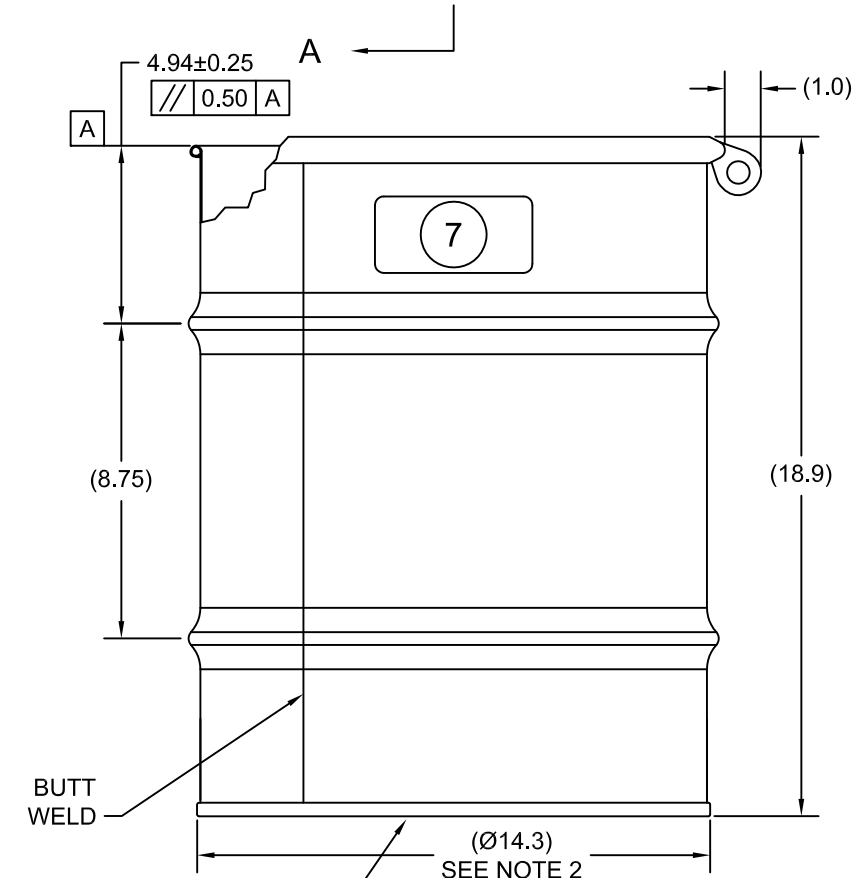

ITEM	P/N	DESCRIPTION	QTY
7		UN DURABLE LABEL	1
6	NT5800	5/8-11UNC HEX JAM NUT	1
5	BT5840	5/8-11UNC X 4in LONG HEAD HEAD BOLT	1
4	RBH1413	BOLT RING (MOD A) 14 ID DRUM 13GA	1
3	GE0503-01	GASKET 3/8 DIA RD EPDM	1
2	P1409S	COVER 14 ID	1
1		BODY/BOTTOM 5 GALLON DRUM 14 ID	1

BUTT WELD

UN NUMBER EMBOSSED ON BOTTOM OF DRUM
1/2" CHARACTERS READING:

UN/1A2/X120/S/YR
UN/1A2/Y1.8/150/YR
0.9 * 304

TARE WEIGHT:
14 lbs

THE USE OF INFORMATION CONTAINED HEREIN IS RESTRICTED FOR THE BENEFIT OF SKOLNIK INDUSTRIES ONLY. UNAUTHORIZED USE OR DISCLOSURE, COPYING OR OTHERWISE REPRODUCING (IN ANY MANNER) ANY PORTION OF THIS DRAWING WITHOUT PRIOR WRITTEN PERMISSION OF AN AUTHORIZED OFFICIAL OF SKOLNIK INDUSTRIES IS STRICTLY PROHIBITED.

MFG JR	DRW LJT	CHK MAR
SLS DR	QA MD	
APR G. Petersen		
FILE CREATED IN AutoCAD 2002		

UNLESS STATED OTHERWISE
(DIMENSIONS IN PARENTHESIS ARE FOR REFERENCE ONLY!!!)
ALL DIMENSIONS ARE IN INCHES
DO NOT SCALE DRAWING
TOLERANCES:
FRACTIONS ±1/4
X° ± 3°
X.X ± 0.2
X.XX ± 0.10
X.XXX ± 0.030

SKOLNIK INDUSTRIES, INC.
4900 SOUTH KILBOURN AVENUE, CHICAGO, IL 60632

DESCRIPTION
10 GALLON OPEN HEAD DRUM
0.9 - 0.9 - 0.9 304SS
1A2/X120/S & 1A2/Y1.8/150

REL. DATE	PART NUM. / FILENAME ST1004	REV A3
-----------	--------------------------------	-----------